

**Service Training**



**Commercial  
Vehicles**

**Self-Study Programme 453**

**For the T5 2010**



## The T5 from Volkswagen Commercial Vehicles

Series production of the first Volkswagen Transporter started in March 1950. An initial production of 10 vehicles per day quickly developed into one of the most successful careers for an automobile, and one which laid the foundation for a new vehicle segment. Multivan and Caravelle also founded a new vehicle segment in which they have continued to set new standards right down to the present day.

Today, as in the past, the Volkswagen Commercial Vehicles brand stands for innovative technology and a product range that is tailored to requirements. At the same time, e.g. TDI®, DSG® and 4MOTION® represent unique technical solutions that are only available in this segment in models from Volkswagen Commercial Vehicles.



S453\_002

The T5 2010 will be available in the following equipment lines:

- Transporter: Panel van, window van, chassis, platform van and back-to-back cab
- Caravelle: Trendline and Comfortline
- California: Beach and Comfortline
- Multivan: Startline, Comfortline, Highline and PanAmericana

---









**The self-study programme shows the design and function of new developments!**  
The content is not updated.

For current inspection and setting instructions, and workshop manuals, please refer to the service literature that is provided.



**Important  
Note**



<b>Introduction</b> .....	<b>4</b>	
The model family of the T5 2010 .....	4	
Technical data .....	6	
<b>Body</b> .....	<b>8</b>	
The body .....	8	
The tailgate emergency unlocking function .....	11	
Occupant protection .....	12	
<b>Engine</b> .....	<b>14</b>	
The engine/gearbox combinations .....	14	
<b>Power transmission</b> .....	<b>20</b>	
The gearboxes .....	20	
The four-wheel drive .....	22	
<b>Chassis</b> .....	<b>28</b>	
Overview of the running gear .....	28	
The brake system .....	30	
The steering .....	34	
<b>Heating and air conditioning</b> .....	<b>38</b>	
The climate control .....	38	
The auxiliary heaters .....	39	
<b>Electrics</b> .....	<b>40</b>	
The installation locations of the control units .....	40	
The networking concept .....	42	
The onboard supply control unit J519 .....	44	
The lights .....	46	
The lane change assist .....	50	
The reversing camera system .....	51	
The dash panel .....	52	
The media device interface box .....	53	
<b>Radio, phone and navigation</b> .....	<b>54</b>	
The radios and radio navigation systems .....	54	
The aerial concept .....	56	
The telephone preparation UHV .....	63	

# Introduction



## The model family of the T5 2010

The 2010 model year will see the launch of an extensive remodeling of what is to become the fifth model generation of the Transporter. Yet again, this vehicle will underline the pioneering role played by Volkswagen Commercial Vehicles in the segment of people carriers and transporters.

In the 2010 model year, the model range also includes the familiar model variants.

- Platform van
- Panel van
- Window van
- Caravelle
- Multivan
- California



Panel van



Window van



Platform van  
(Example: double cab)

Overview of the most important highlights:

- new TDI® engines with common rail injection system, 7-speed dual clutch gearbox, 4MOTION with dual clutch gearbox and Servotronic,
- Multivan now also with long wheelbase,
- new driver assistance systems, new infotainment programme and new air conditioning controls,
- new "fresh" design in the interior, e.g. new instrument clusters, new fabrics and steering wheels and new decor for the galley in the California,
- attractive exterior, e.g. with new exterior mirrors, engine cover, headlights, front end, tail lights, rims and a new range of colours,
- increased operating comfort.



The new T5 2010 consistently implements the new design language of Volkswagen.

- A clear face - high quality and timeless,
- The horizontal, clean lines make the vehicle look wide and have great presence on the road.
- Its eyes - open, unique and self-assured.
- The night design of the new tail lights in the Multivan with Volkswagen Commercial Vehicle's own signature - its appearance on the road is immediately recognisable.
- Panel van, window van and platform van with robust and solid, grey grained front and rear bumpers corresponding to the type of vehicle
- Multivan, Caravelle and California with painted front and rear bumpers - this underlines the clear, high-quality character.

The design revisions consistently support the character properties of the new T5 2010.

Multivan



Caravelle



S453\_122

California



About the model range:

- Predominantly for transporting people - window van, Caravelle, Multivan, California.
- In the other versions, the T5 2010 is chiefly used for transporting loads.
- Within the model range, there are versions with both a short and a long wheelbase and three different roof heights.
- The maximum possible payloads of the vehicles vary depending on the different operating conditions.
- Some model variants are available with four-wheel drive (4MOTION).



# Introduction



## Technical data

### Platform van

Platform van  
Single cab

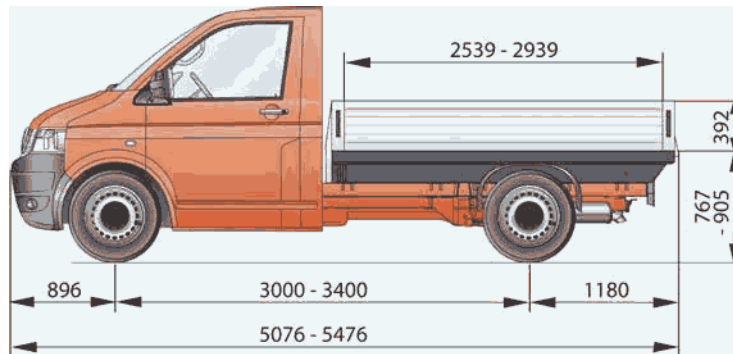

S453\_004

Platform van  
Double cab

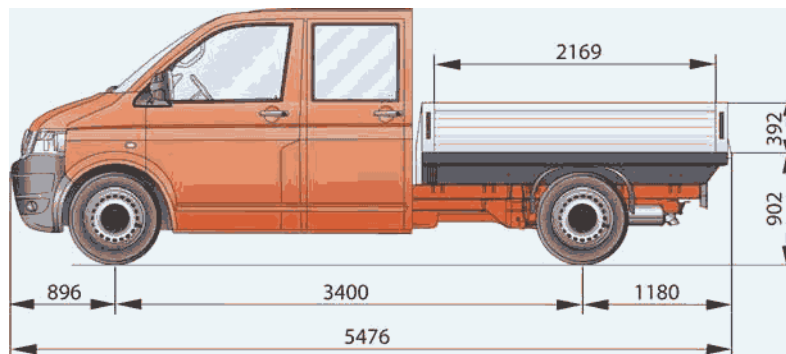

S453\_104

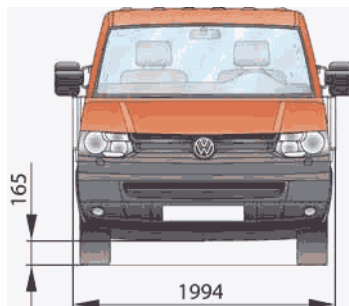

S453\_005

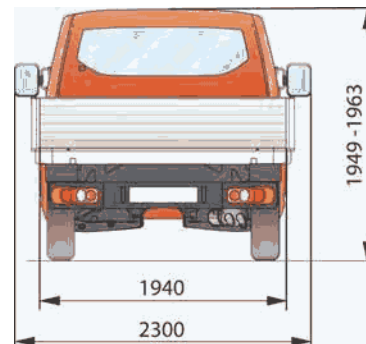

S453\_006



The pictures only show selected variants and their dimensions/dimension ranges (e.g. with short and long wheelbase, etc.) - the chassis is not shown here. Please refer to the current sales literature for the complete set of technical data for the model range.



## Panel van, window van, Caravelle, Multivan, California

Panel van

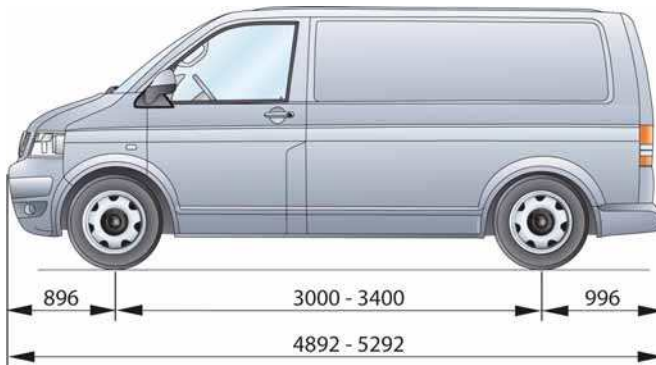

S453\_117

Multivan

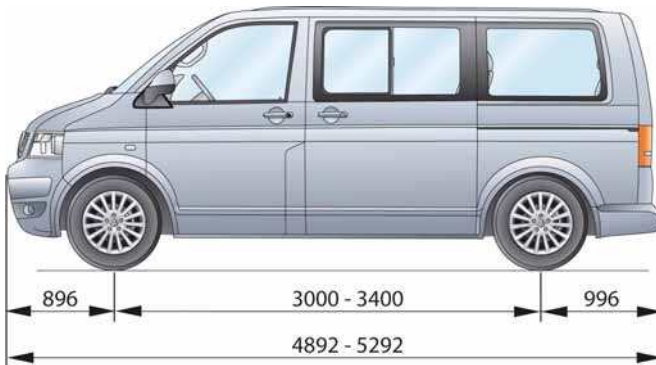

With the launch of the T5 2010, the Multivan will also be available with a long wheelbase.

S453\_029

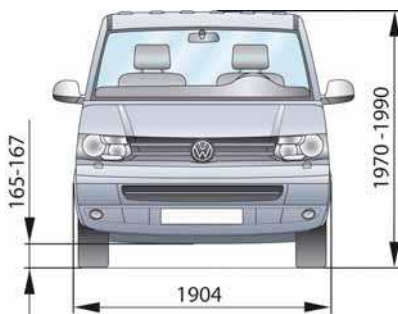

S453\_030

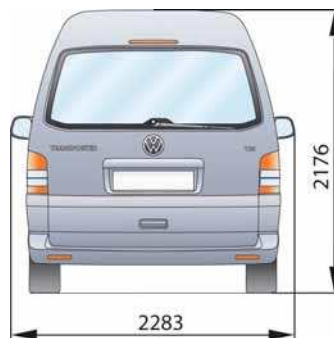

S453\_031



S453\_145



The pictures only show selected variants and their dimensions/dimension ranges (e.g. short and long wheelbase, normal roof, medium-high roof and high roof depending on the versions, etc.). Please refer to the current sales literature for the complete set of technical data for the model range.

## The body

To a large extent, the body has been taken from the previous model.

The front end is new - it has been adapted to the current face of the Volkswagen family and is the same for the Multivan and commercial vehicles. The engine cover and the exterior mirrors have been improved in terms of their aerodynamics and reduced wind noise.

Acoustic glazing is also available as an option.

Innovations on the front end in detail:

- An engine cover with new lines and more angular beading
- The engine cover extends further upwards and covers the wiper arms in the windscreen area.
- In the lower area, the engine cover extends further into the radiator grille area.
- The front end has a new assembly mount.
- New exterior mirrors
- New radiator grille
- Modified VW emblem design
- New headlights



S453\_131

## Front end

The front end is composed of the following main components:

- Assembly mount
- Bumper mount
- Bulkhead
- Ventilator
- Radiator
- Condenser
- Intercooler (in the variants for TDI engine and TDI engine with bi-turbocharger unit)
- Cooler for power steering

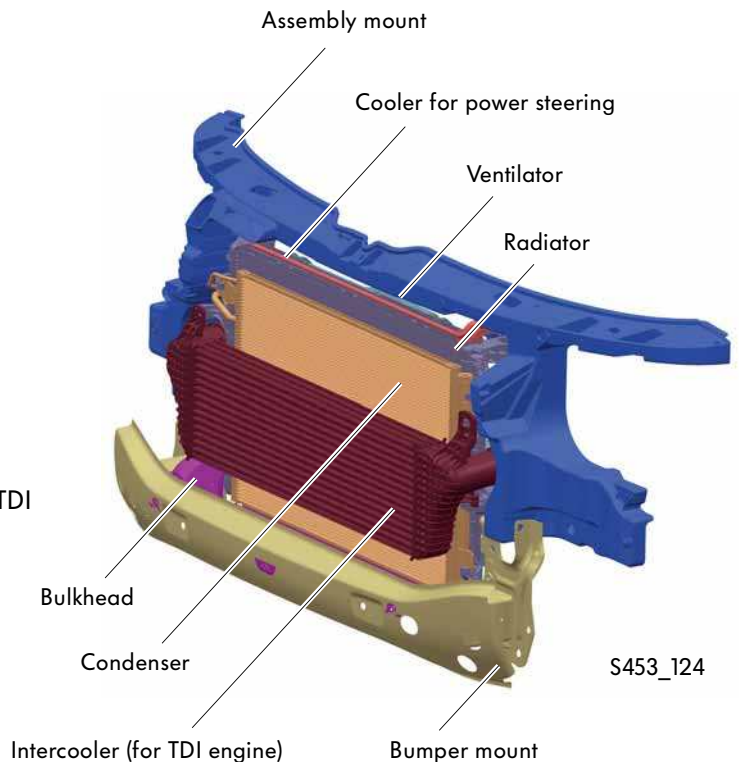

S453\_124



## Structure of the front end - exploded view

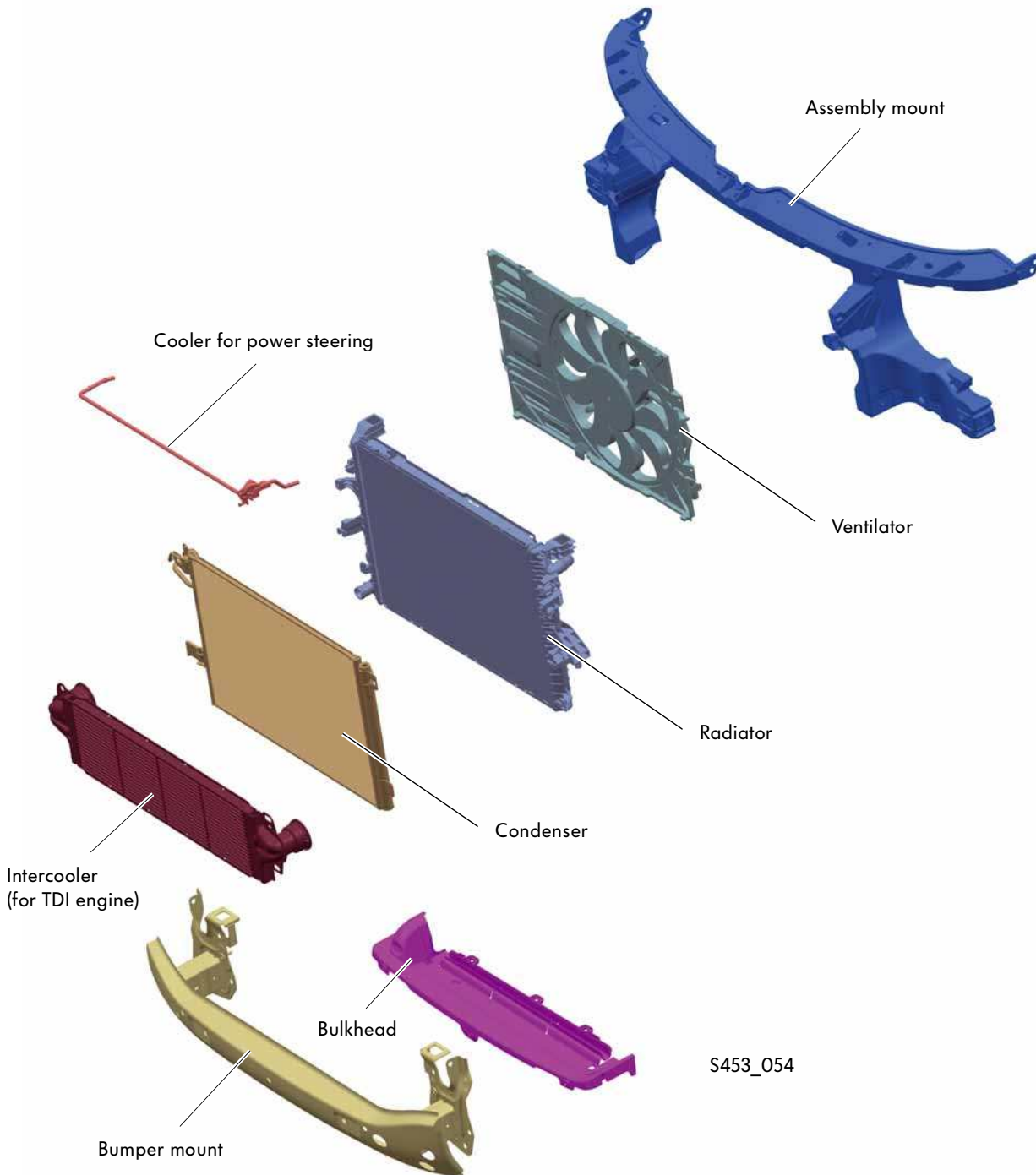

The double fan concept in the previous model will be discontinued - the T5 2010 now has a single fan exclusively. The cooling power is adapted to the equipment level by means of three different fan powers (450 W, 600 W, 850 W).



The attachments for all components on the assembly mount have changed. Please always refer to the information in the workshop manual.

# Body

## Assembly mount

In contrast to the assembly mount in the previous model, the one in the T5 2010 is no longer made from steel but from a composite material comprising plastic with a steel insert. The main advantage is the increased weight saving.

In order to guarantee the necessary stability and crash safety of the assembly mount, the upper cross member of the assembly mount has been fitted with a steel insert. The plastic part is connected to the steel insert by hot riveting. This involves the steel insert being pushed onto the extruded projections of the plastic part, and then riveted by compression under the effect of heat.

All other parts of the assembly mount are made entirely of plastic.

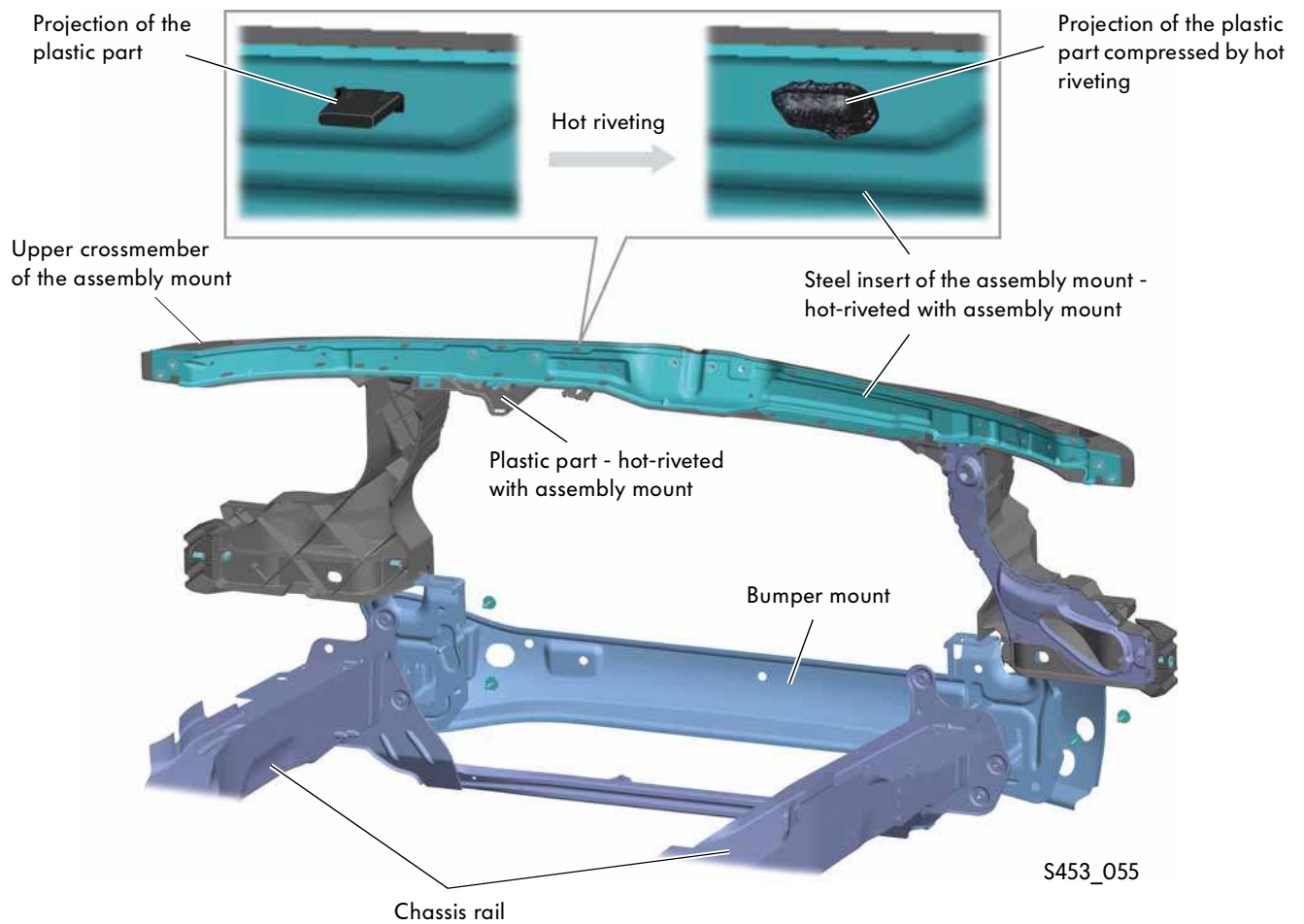

It is essential to comply with the information in the workshop manual with regard to repair work on the front end - this applies in particular to the service position as well

## The tailgate emergency unlocking function

All model variants of the T5 2010 with tailgate are equipped with a tailgate emergency unlocking function. In case of an emergency when the tailgate can no longer be opened, e.g. because:

- The tailgate or the opening mechanism has been damaged due to a crash
- The central locking has failed
- The opening system has failed on an electrically operated tailgate

then it is possible to open the tailgate from the inside.

The emergency unlocking function is installed on the tailgate above the tailgate lock behind a plastic cover. The cover cap is identified with the "opened tailgate" symbol.

After the cover cap has been removed, the emergency unlocking function can be actuated manually by pressing the lever for the emergency unlocking function.

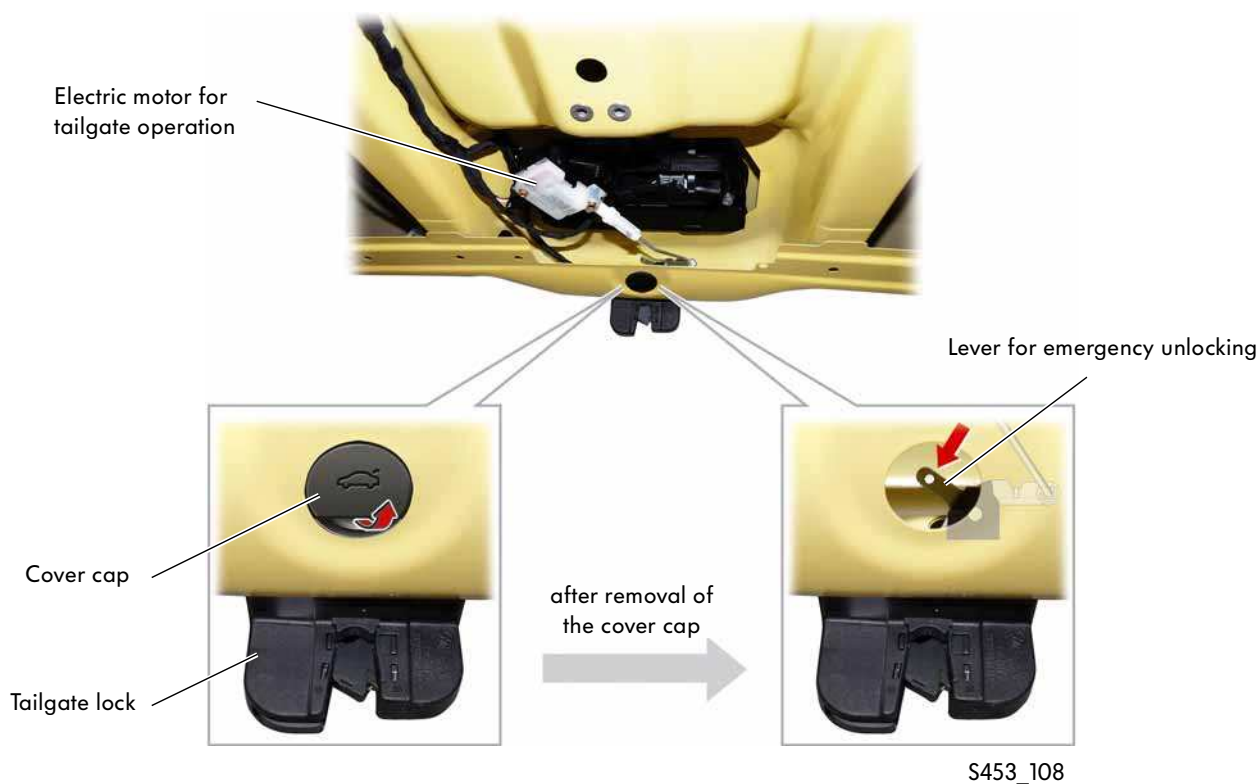

Also refer to the owner's manual for information about the emergency unlocking function.

## Occupant protection

As a feature of the Volkswagen safety strategy, the occupant protection system in the T5 2010 has been improved in the form of a seat belt fastening warning and a modified airbag concept for driver and front passenger protection.



### Front passenger airbag deactivation

Front passenger airbag deactivation is another safety measure. The front passenger airbag can be deactivated when the passenger door is open, using the key-operated switch on the right-hand side end of the dash panel.



In the commercial vehicle variants, the belts at each of the outboard positions are integrated in the body and those for the middle seat positions are integrated in the seat.



S453\_045

Key operated switch to deactivate front passenger side airbag E224

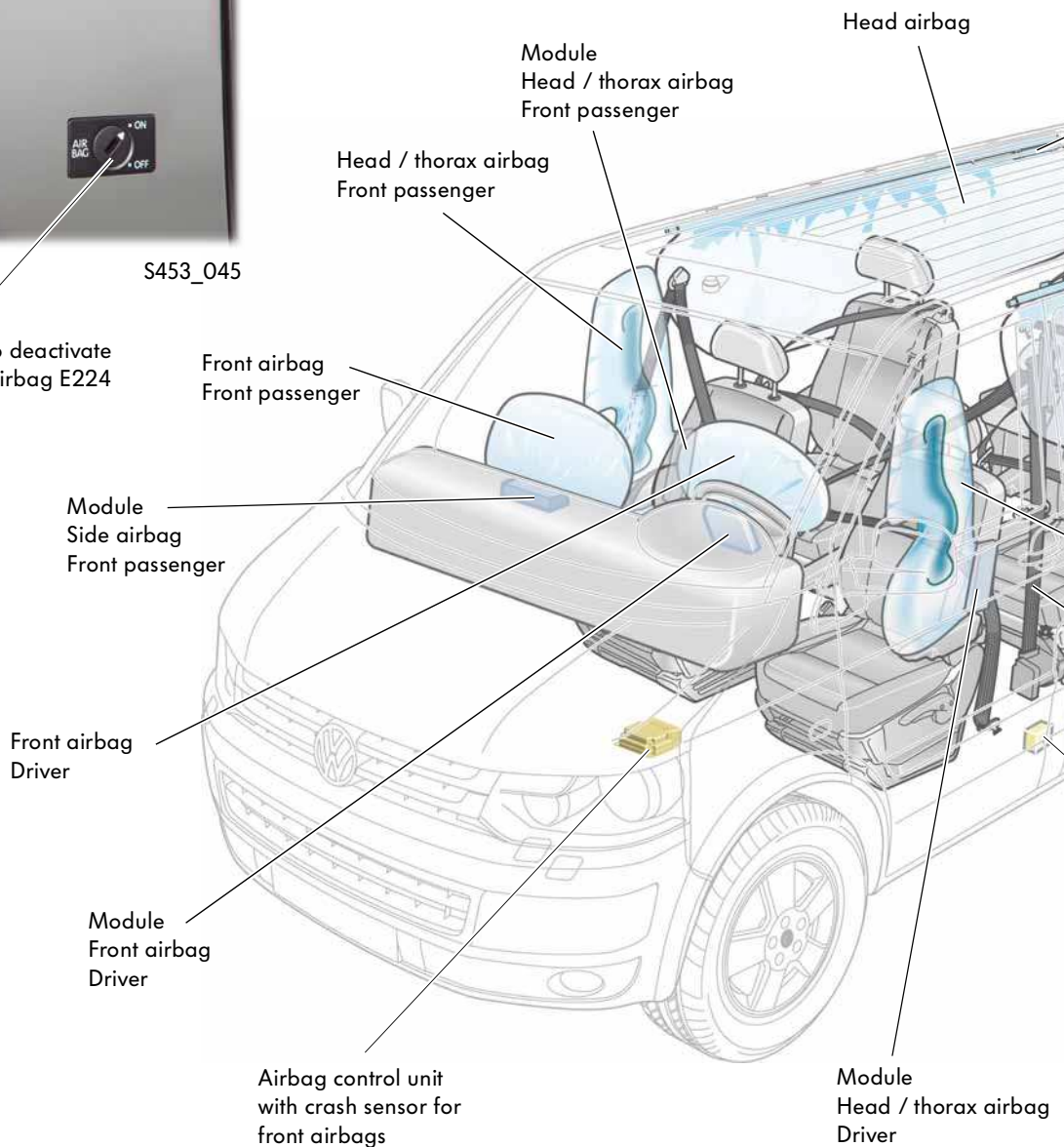



ISOFIX child seat restraint systems are installed in the Multivan in the individual seats and, in the commercial vehicles, the outboard seats in the 1st row of the passenger compartment.

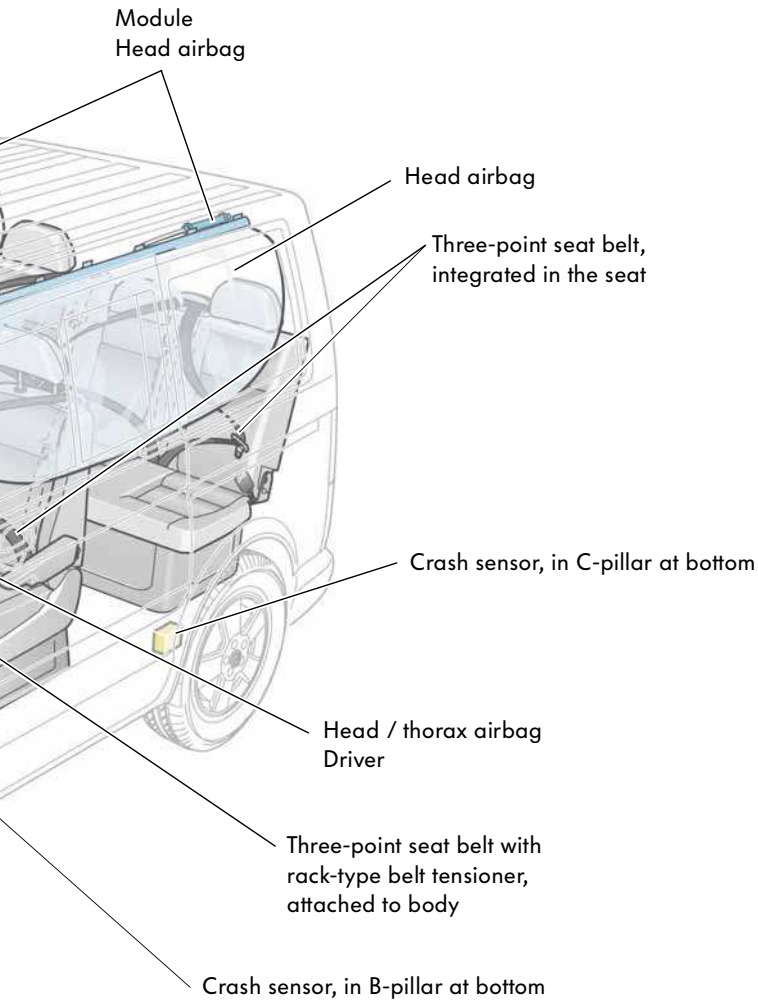

S453\_007

## Belt fastening warning

One feature in the safety concept is the seat belt fastening warning for the driver's seat which is installed as standard. An acoustic signal sounds if the driver's seat belt is not fastened. In addition, a red warning lamp lights up in the instrument cluster.



S453\_123

## Head / thorax airbag

As a new feature, head / thorax airbags are now fitted rather than the previously separate side and head airbags in the passenger compartment. This means the former two systems for each seat are now combined into one system.



Head / thorax airbag Driver

S453\_121

















# Engine

## The engine/gearbox combinations

The engine range includes one petrol and four TDI engines. The power plants are installed transversely.

As far as the gearboxes are concerned, there are 2 manual gearboxes and one automatic.

Engine		5-speed manual gearbox O2Z	6-speed manual gearbox OA5	DSG automatic gearbox OBT
2.0 I/85 kW petrol engine AXA				
2.0 I/62 kW TDI engine CAAA				
2.0 I/75 kW TDI engine CAAB				
2.0 I/103 kW TDI engine CAAC, CCHA				
2.0 I/132 kW TDI engine CFCA				

## 2.0 I/85 kW petrol engine

The engine has been adapted for use in the T5 2010 with the modified installation position.

### Technical features

- Spray nozzles for piston cooling
- Oil pump driven by chain from the crankshaft
- Electrically heated crankcase ventilation
- Secondary air system



S453\_017

### Technical data

Engine identification letter	AXA
Cubic capacity	1984 cm <sup>3</sup>
Design	4-cylinder inline engine
Valves per cylinder	2
Bore	82.5 mm
Stroke	92.8 mm
Compression ratio	10.3 : 1
Max. power	85 kW at 5200 rpm
Max. torque	170 Nm at 2700 rpm up to 4700 rpm
Engine management	BOSCH Motronic ME 7.5
Fuel	Super unleaded with ROZ 98
Exhaust post-treatment	Pre- and post-cat lambda probes with continuous lambda control, exhaust gas recirculation
Emissions standard	EU5, EU4, EU3

### Torque and power diagram

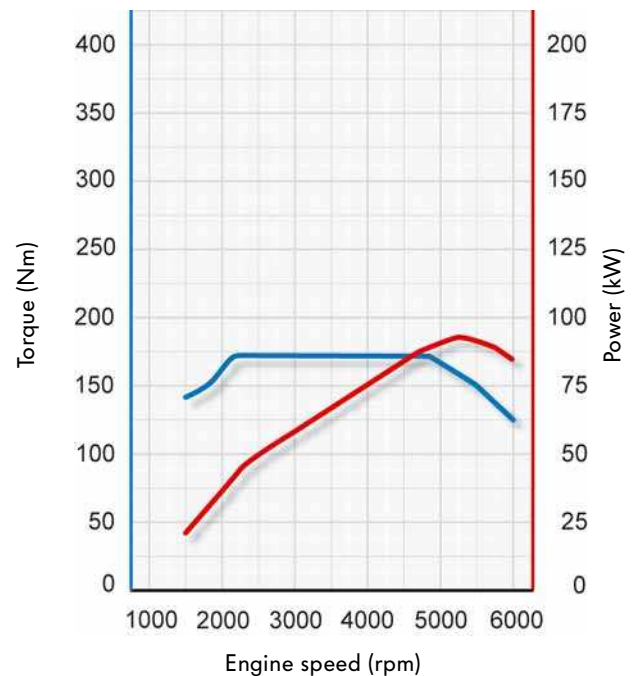

S453\_018



# Engine

## 2.0 I/62 kW TDI engine

The diesel engine is a further development (2nd generation) based on the 2.0 I TDI engine in the Tiguan or Passat, which has been adapted for the installation conditions and the specific commercial vehicle requirements of the T5 2010.

### Technical features

- Common rail injection system
- Diesel particulate filter (EU 5)
- Exhaust gas recirculation through the cylinder head
- Plastic intake manifold
- VTG turbocharger



S453\_013

### Technical data

Engine identification letter	CAAA
Cubic capacity	1968 cm <sup>3</sup>
Design	4-cylinder in-line engine
Valves per cylinder	4
Bore	81.0 mm
Stroke	95.5 mm
Compression ratio	16.5 : 1
Max. power	62 kW at 3500 rpm
Max. torque	220 Nm at 1250 rpm up to 2500 rpm
Engine management	EDC 17CP 20
Fuel	Diesel acc. to DIN EN 590
Exhaust turbocharger	VTG turbocharger
Exhaust gas recirculation	yes
Emissions standard	EU5 with diesel particulate filter EU4 without diesel particulate filter EU3 without diesel particulate filter

### Torque and power diagram

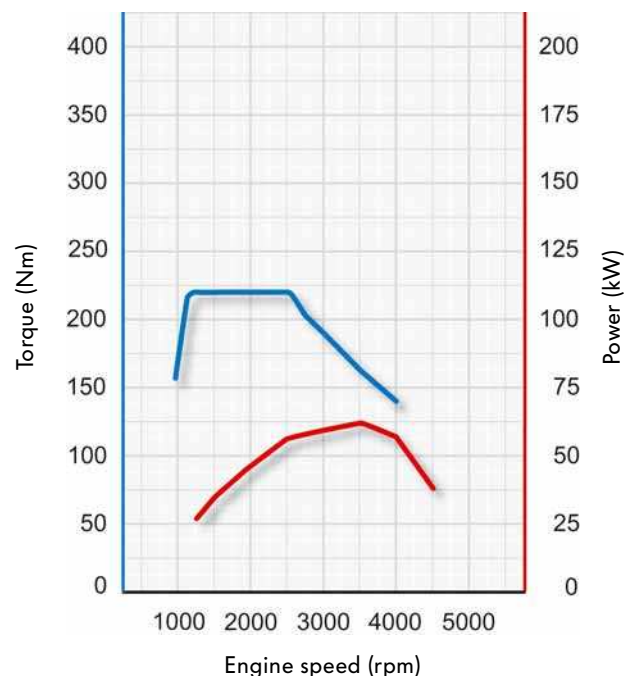

S453\_011

## 2.0 I/75 kW TDI engine

The design of the 75 kW engine is based on the same engine as the 62 kW engine. The difference is only the modification to the control unit software used for the injection system.

### Technical features

- Common rail injection system
- Diesel particulate filter (EU 5)
- Exhaust gas recirculation through the cylinder head
- Plastic intake manifold
- VTG turbocharger



S453\_013

### Technical data

Engine identification letter	CAAB
Cubic capacity	1968 cm <sup>3</sup>
Design	4-cylinder in-line engine
Valves per cylinder	4
Bore	81.0 mm
Stroke	95.5 mm
Compression ratio	16.5 : 1
Max. power	75 kW at 3500 rpm
Max. torque	250 Nm at 1500 rpm up to 2500 rpm
Engine management	EDC 17CP 20
Fuel	Diesel acc. to DIN EN 590
Turbocharger	VTG turbocharger
Exhaust gas recirculation	yes
Emissions standard	EU5 w. diesel particulate filter EU4 without diesel particulate filter EU3 without diesel particulate filter

### Torque and power diagram

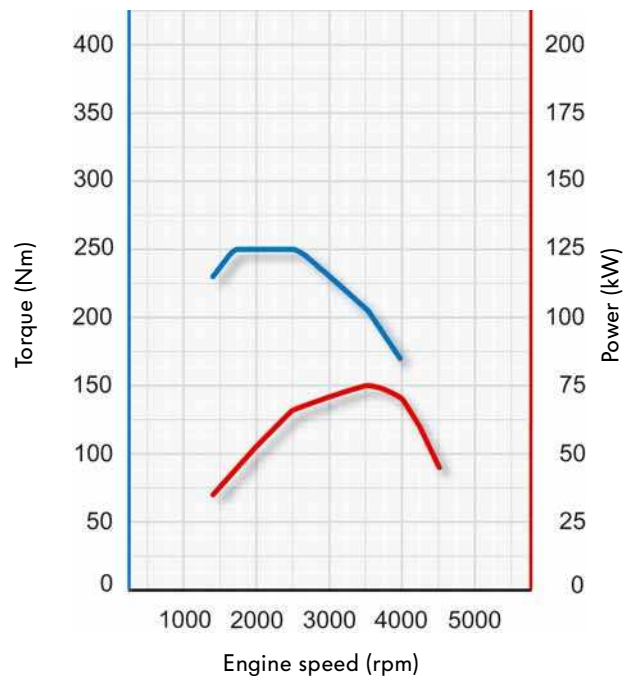

S453\_012

# Engine

## 2.0 I/103 kW TDI engine

The design of the 2.0 I/103 kW engine is also based on the same engine as the 62 kW engine. The difference is only the modification to the control unit software used for the injection system.

### Technical features

- Common rail injection system
- Diesel particulate filter (EU 5)
- Exhaust gas recirculation through the cylinder head
- Plastic intake manifold
- VTG turbocharger



S453\_013

### Technical data

Engine identification letter	CAAC - Transporter version CCHA - Multivan, Caravelle
Cubic capacity	1968 cm <sup>3</sup>
Design	4-cylinder in-line engine
Valves per cylinder	4
Bore	81.0 mm
Stroke	95.5 mm
Compression ratio	16.5 : 1
Max. power	103 kW at 3500 rpm
Max. torque	340 Nm at 1750 rpm up to 2500 rpm
Engine management	EDC 17CP 20
Fuel	Diesel acc. to DIN EN 590
Turbocharger	VTG turbocharger
Exhaust gas recirculation	yes
Emissions standard	EU5 w. diesel particulate filter EU4 w/o diesel particulate filter EU3 without diesel particulate filter

### Torque and power diagram

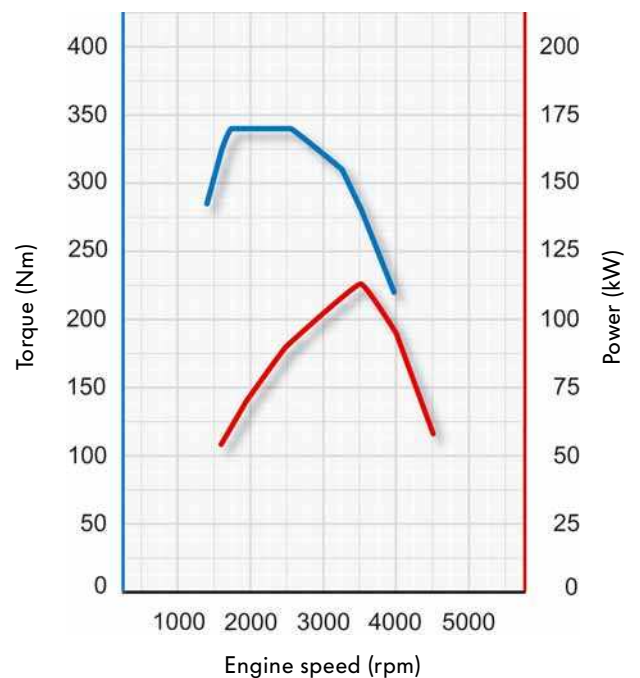

S453\_014



## 2.0 I/132 kW TDI engine with bi-turbo unit

The design of the 2.0 I/132 kW engine is based on the 2.0 I/103 kW engine, but it is equipped with a bi-turbo unit to provide a power boost. The control unit software has been adapted accordingly.

### Technical features (in addition to the 2.0 I/103 kW engine)

- Exhaust manifold module with bi-turbo unit
- Oil filter module with integrated exhaust gas recirculation cooler
- Cylinder block with additional cooling ducts
- Piston with cooled ring groove



S453\_015

### Technical data

Engine identification letter	CFCA
Cubic capacity	1968 cm <sup>3</sup>
Design	4-cylinder in-line engine
Valves per cylinder	4
Bore	81.0 mm
Stroke	95.5 mm
Compression ratio	16.5 : 1
Max. power	132 kW at 4000 rpm
Max. torque	400 Nm at 1500 rpm up to 2250 rpm
Engine management	EDC 17 CP 20
Fuel	Diesel acc. to DIN EN 590
Exhaust turbocharger	Bi-turbo unit
Exhaust gas recirculation	yes
Emissions standard	EU5 w. diesel particulate filter EU4 without diesel particulate filter EU3 without diesel particulate filter

### Torque and power diagram

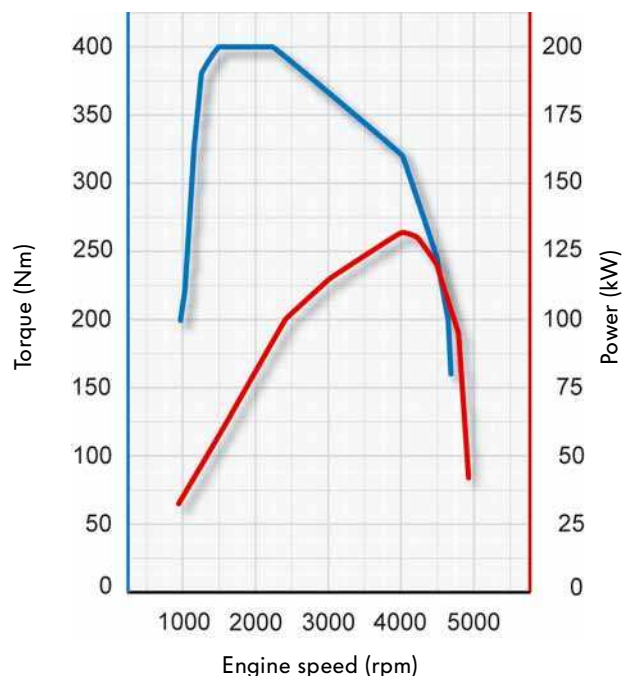

S453\_016



# Power transmission

## The gearboxes

Two manual gearboxes, the 02Z and the 0A5 gearbox, and the DSG automatic gearbox 0BT are used in the T5 2010. They have been designed for transverse installation in the vehicle.

### 5-speed manual gearbox 02Z

The 5-speed gearbox is already familiar from the previous model, and is used with the 4-cylinder 85 kW petrol engine and the 4-cylinder TDI engines with 62/75 kW. The gearbox can transmit torques up to a maximum of 250 Nm.



S453\_026

### 6-speed manual gearbox 0A5

The 6-speed gearbox is also familiar from the previous model and is used in the 4-cylinder TDI engines with 103/132 kW. It can transmit torques up to a maximum of 500 Nm.

The compact design is convenient for transverse installation, and has been achieved by structuring it as a 4-shaft gearbox. In the 4-shaft concept, the pinion shafts are permanently engaged with the gear on the final drive.

Depending on which gear is engaged, the powerflow is via the input shaft onto one of the pinion shafts.

The clutch bell housing has been adapted to the modified installation situation in order for it to be fitted on the 4-cylinder TDI engine.



S453\_025

## 7-speed dual clutch gearbox OBT

The 7-speed dual clutch gearbox (DSG) OBT is being used in the T5 2010 for the first time in the Volkswagen Group. From March 2010, it will be possible to combine the DSG with four-wheel drive in the T5 2010. It can also be used in heavy vehicles with a gross vehicle weight rating of up to 3.2 t. The OBT gearbox is designed for input torques of up to 600 Nm.

The 7-speed DSG will initially only be used in 103 kW and 132 kW TDI engines. In terms of its mechanical and control systems, it represents a significant further development on the previously familiar dual clutch gearbox.

The OBT gearbox has been developed entirely within Volkswagen, and is also produced within the company, to very high manufacturing standards.



S453\_019



All-in-all, it represents a milestone in the gearbox strategy of the Volkswagen Group, which means it contributes to a further expansion in the technological lead enjoyed by Volkswagen.

### Advantages of the 7-speed DSG at a glance:

- Reductions in fuel consumption and CO<sub>2</sub> emissions
- Expansion and further development of expertise relevant for the competition in dual clutch gearboxes
- This now permits four-wheel drive with an automatic gearbox
- Winning over manual gearbox customers
- With the 7-speed DSG, Volkswagen is securing its market leadership in the Transporter segment



For further information about this gearbox and its selector mechanism, refer to self-study programme no. 454 "The 7-speed dual clutch gearbox OBT".

## Tachograph

In vehicles with a tachograph, it is a requirement to have a separate speed signal for recording the vehicle's speed on the tachograph. The vehicle speed for the tachograph continues to be taken directly from the gearbox. It is now possible to retrofit a speedometer sender on all gearboxes. There are two different gearbox-specific speedometer senders for the T5.

# Power transmission

## The four-wheel drive

In the T5 2010, four-wheel drive is available in all vehicle variants in conjunction with the 2.0 l 103/132 kW TDI engines.

It can be used with the 6-speed manual gearbox OA5 and now, for the first time, also in conjunction with an automatic gearbox - the 7-speed dual clutch gearbox OBT.

A Haldex 4th generation coupling is used as the 4WD coupling.

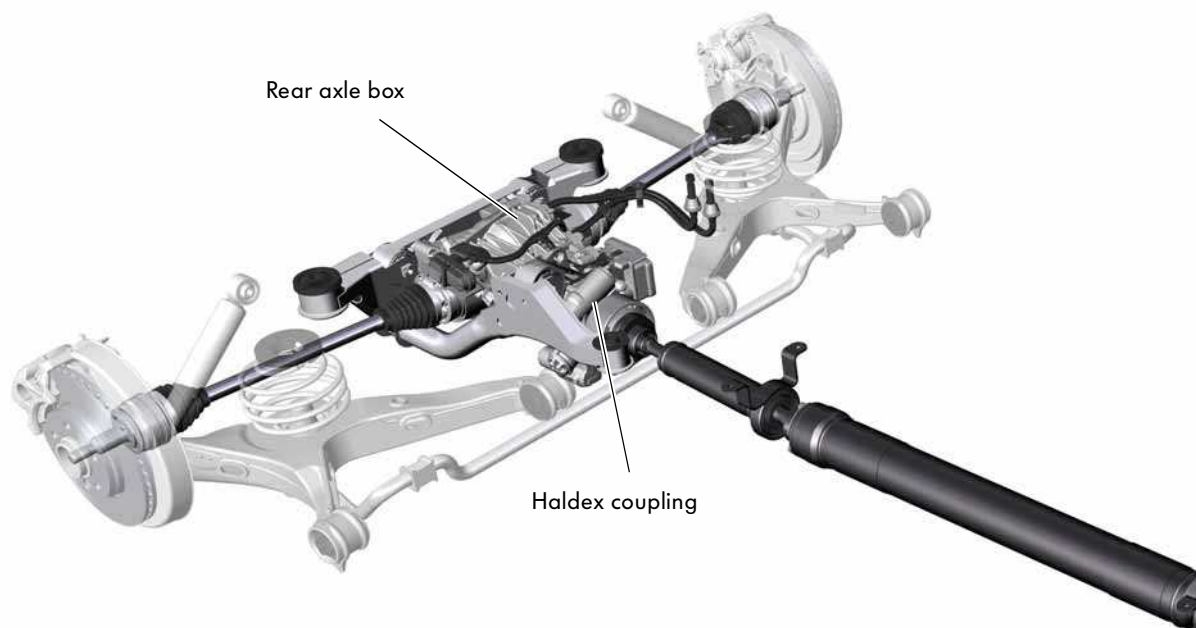

### Rear axle box

The design of the rear axle box has been adapted for installation of the Haldex 4th generation coupling and for the higher torque requirements in the T5 2010.

As an option, the T5 2010 is available with a mechanical differential lock comprising a dog clutch on the rear axle box.



The picture shows the four-wheel drive system as an example in conjunction with a dual clutch gearbox.

## Bevel drive

The bevel drive has been adapted for the higher torque requirements in the T5 2010.

Two different bevel drives are used, one of which is adapted for mounting on the manual gearbox and the other for the dual clutch gearbox.

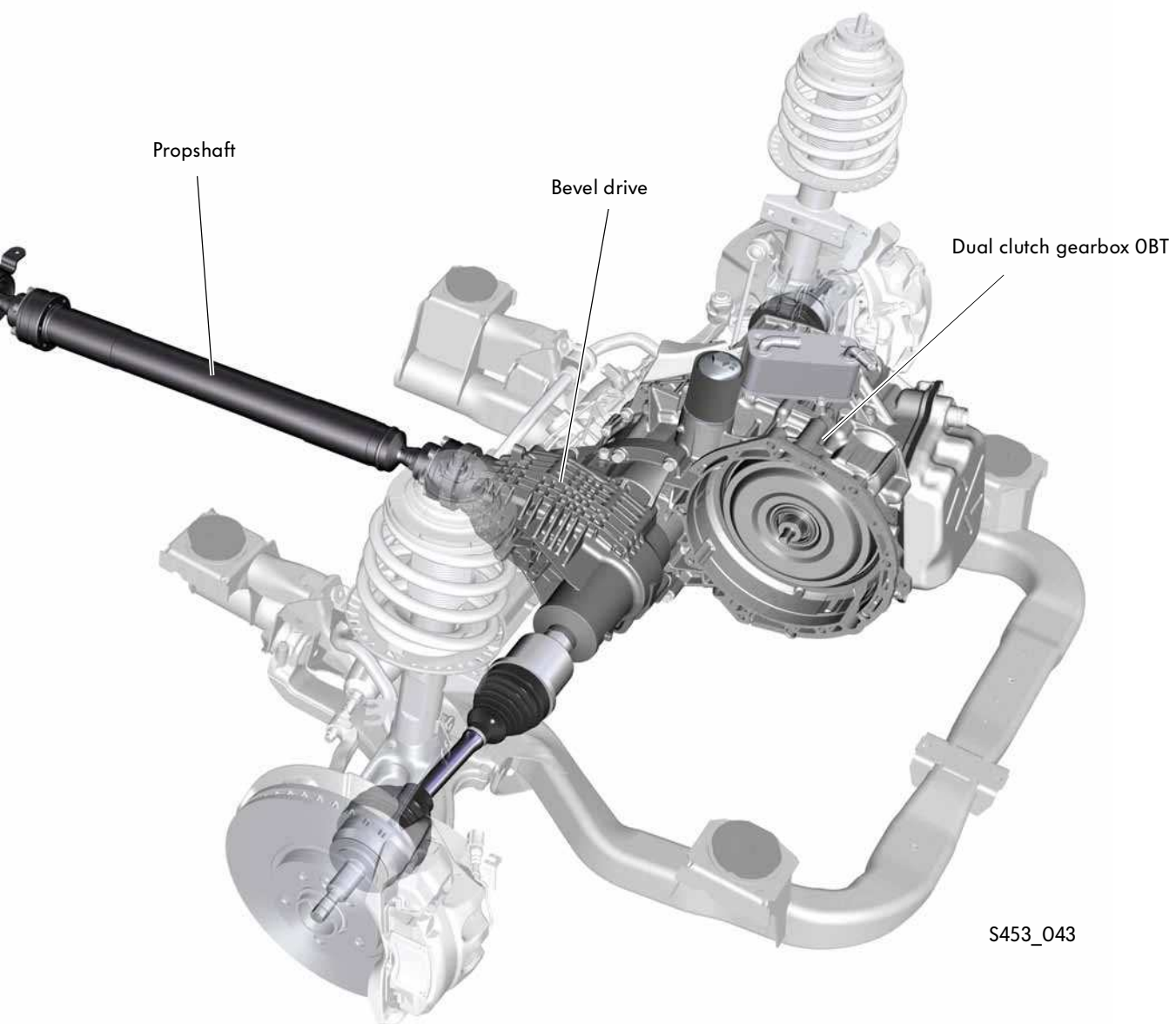

S453\_043





# Power transmission

## Bevel box

The housing structure, the bearings and the gears of the bevel box have been adapted for the higher torque requirements in the T5 2010. At the same time, it has been possible to reduce the weight of the bevel box by 6.25 kg compared to the previous type.

## Structure and function

The bevel box is driven via a hollow shaft with inner spines. This hollow shaft is a component of the bevel box and is positively connected to the housing of the differential via its splines. The spur gear on the hollow shaft transmits the torque onto the intermediate shaft with hypoid gearing and subsequently to the propshaft via the pinion. The stub shaft for the right front wheel runs inside the hollow shaft. This stub shaft is driven by the shaft bevel gear of the differential.

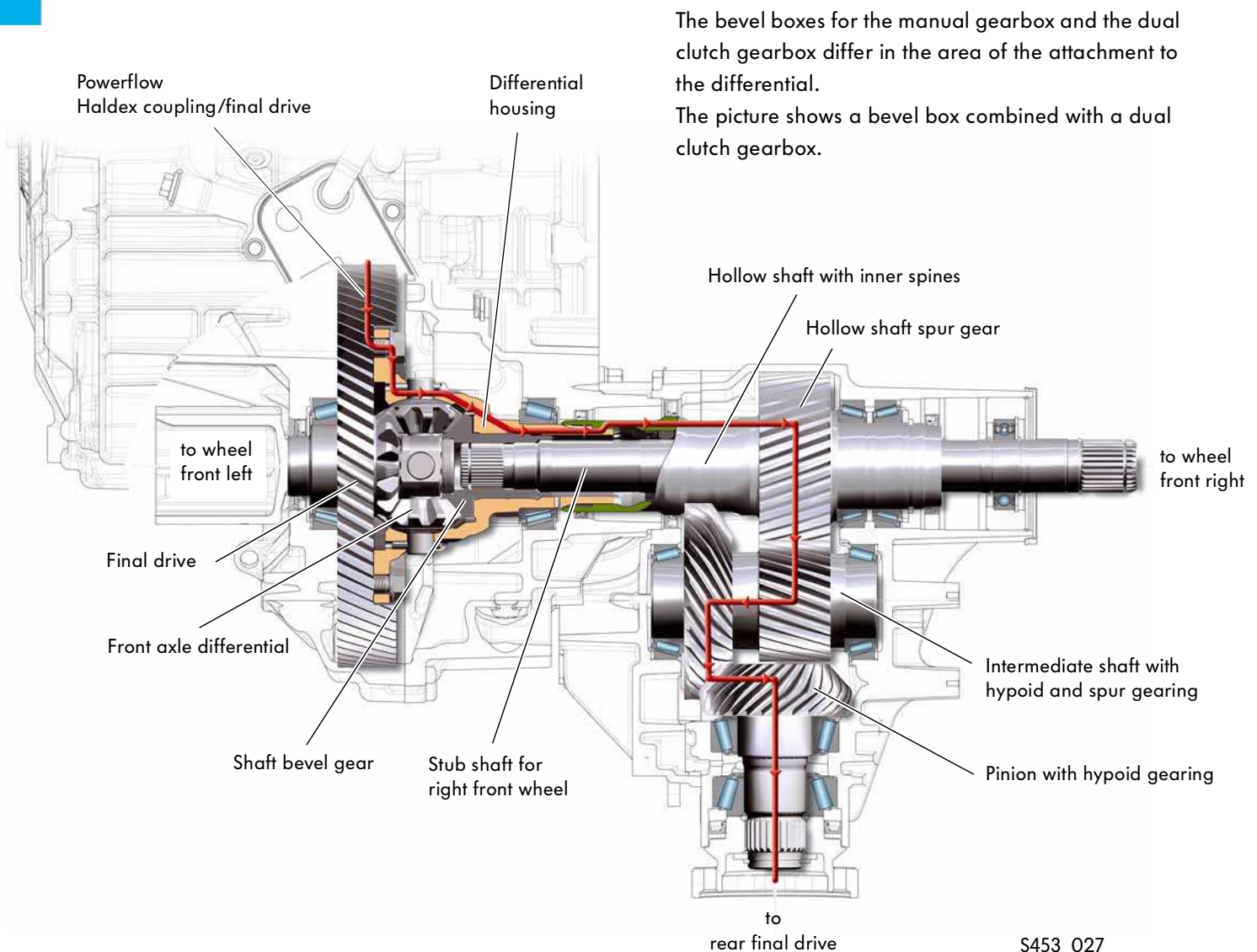

The bevel boxes for the manual gearbox and the dual clutch gearbox differ in the area of the attachment to the differential.

The picture shows a bevel box combined with a dual clutch gearbox.

## Rear final drive

The design of the rear final drive has been adapted for installation of the Haldex 4th generation coupling and for the higher torque requirements in the T5 2010, as far as the housing and the bearings are concerned.

The reservoir tank for the Haldex oil is an integral component of the final drive housing. This means it is protected against mechanical damage from the outside.

The Haldex 4th generation coupling is similar in design to the Haldex coupling in the Caddy and Tiguan.

Optionally, the rear axle drive is available with a mechanical differential lock.



More information about the Haldex 4th generation coupling is available in self-study programme no. 414 "4MOTION with generation IV 4WD coupling".

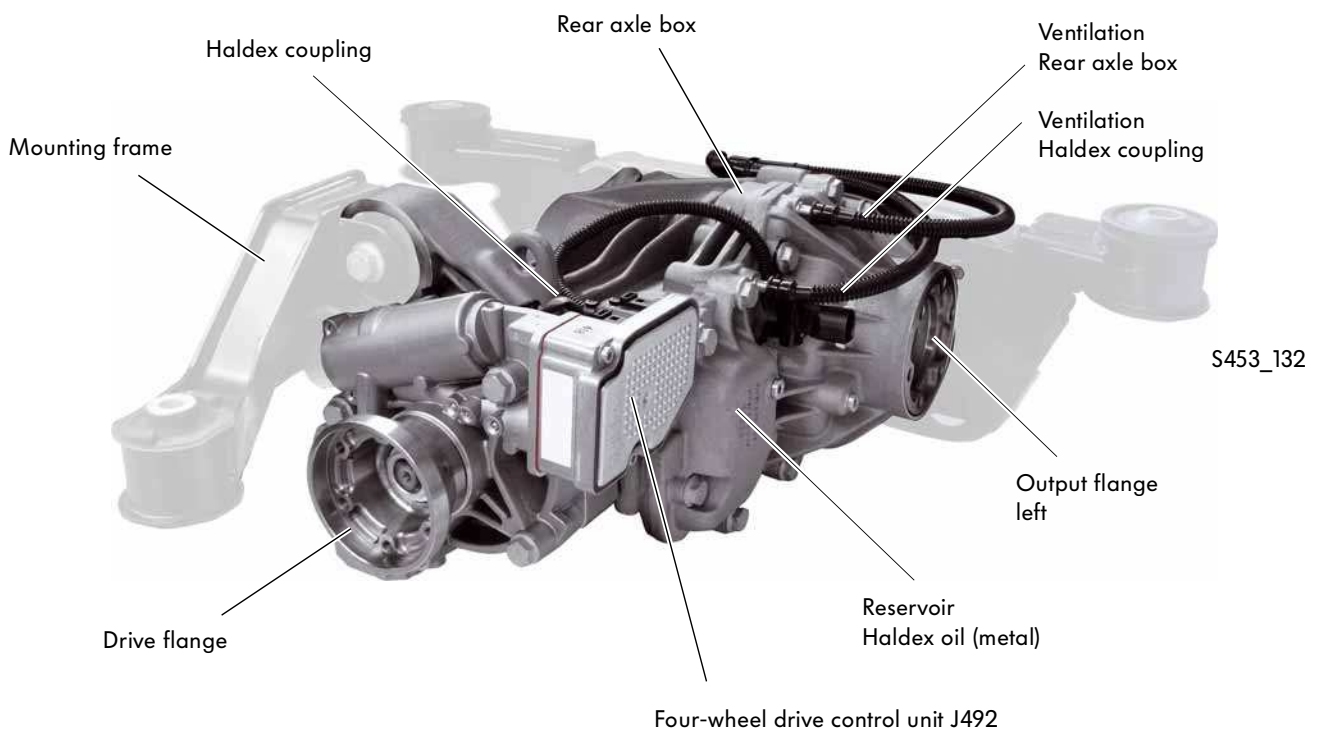

When service work is carried out on the rear axle box, refer to the information in ELSA (Electronic Service Information System) or in the technical product information documents. This applies to the oil fills in particular. Never mix up oils for the rear axle box and for the Haldex coupling with one another! If oils are mixed up or there is no oil fill, there will be massive damage to the final drive and/or the Haldex coupling.

# Power transmission

## Cutaway view – rear axle box

The rear final drive of the four-wheel drive T5 2010 consists of the Haldex 4th generation coupling, the final drive and the optionally available differential lock. The transmission ratio is 2.466.

The Haldex coupling is integrated into the final drive and can be renewed separately.

The oil supply to the Haldex coupling and the final drive comes from two different oil circuits. Two oils adapted to the particular requirements are used for lubrication and cooling.

The two oil circuits are sealed off from one another internally by a double oil seal.

This separates both the oil circuits from one another. There is a spacer between the two halves of the double oil seal, in order to guarantee that there will be a narrow gap. The gap is connected to the atmosphere by means of a breather hole in order to equalise the pressure.

In the event of a leak of the pinion, it is possible for leaking Haldex or final drive oil to reach the outside via the breather hole.

The double oil seal prevents any mixing between the two oils.

Mixing would impair the lubrication properties of both oils, and could result in malfunctions in the final drive or in the Haldex coupling.

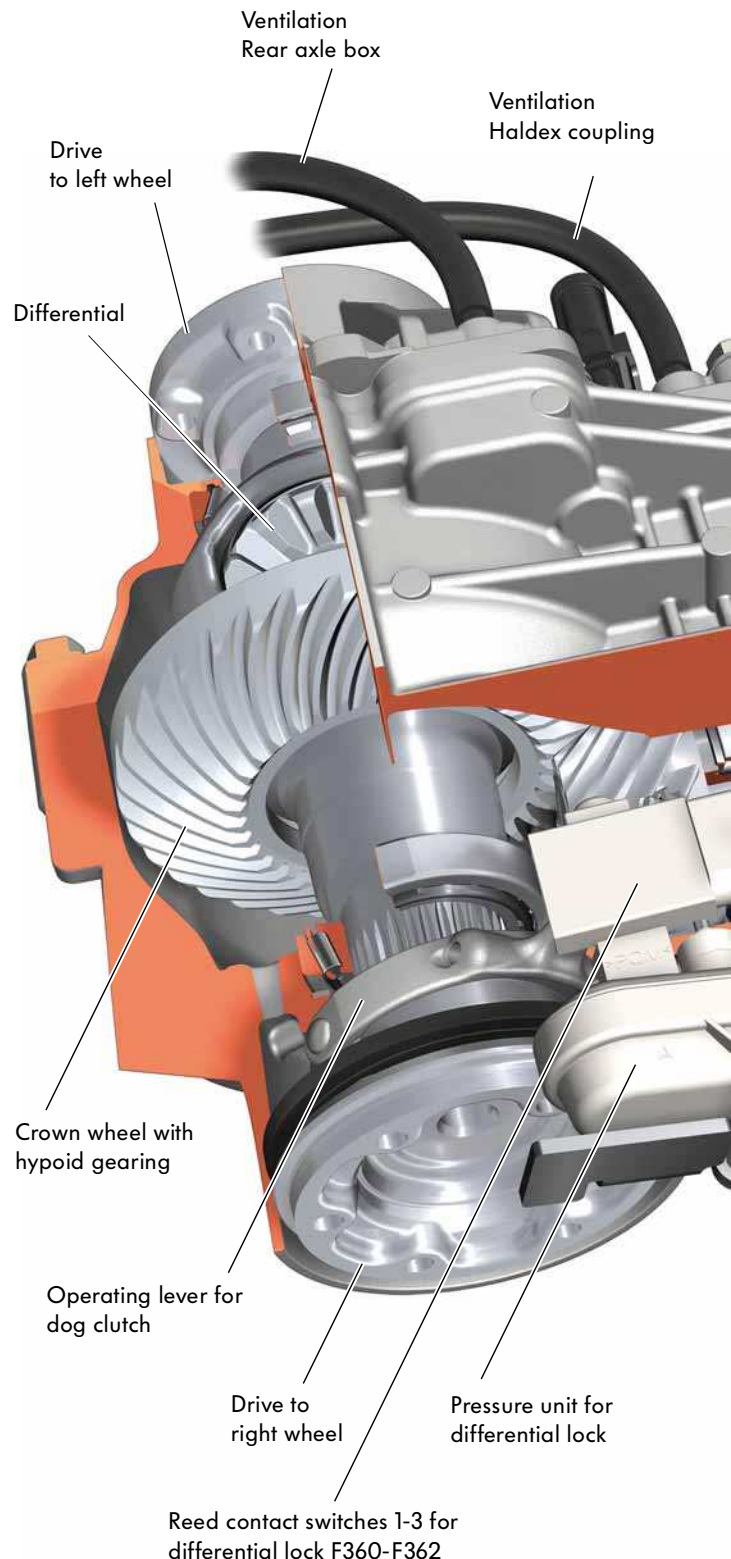

For more information about the differential lock, refer to self-study programme no. 333 "4MOTION with Haldex coupling".



For more information about the Haldex 4th generation coupling, refer to self-study programme no. 414 "4MOTION with Haldex 4th generation coupling".

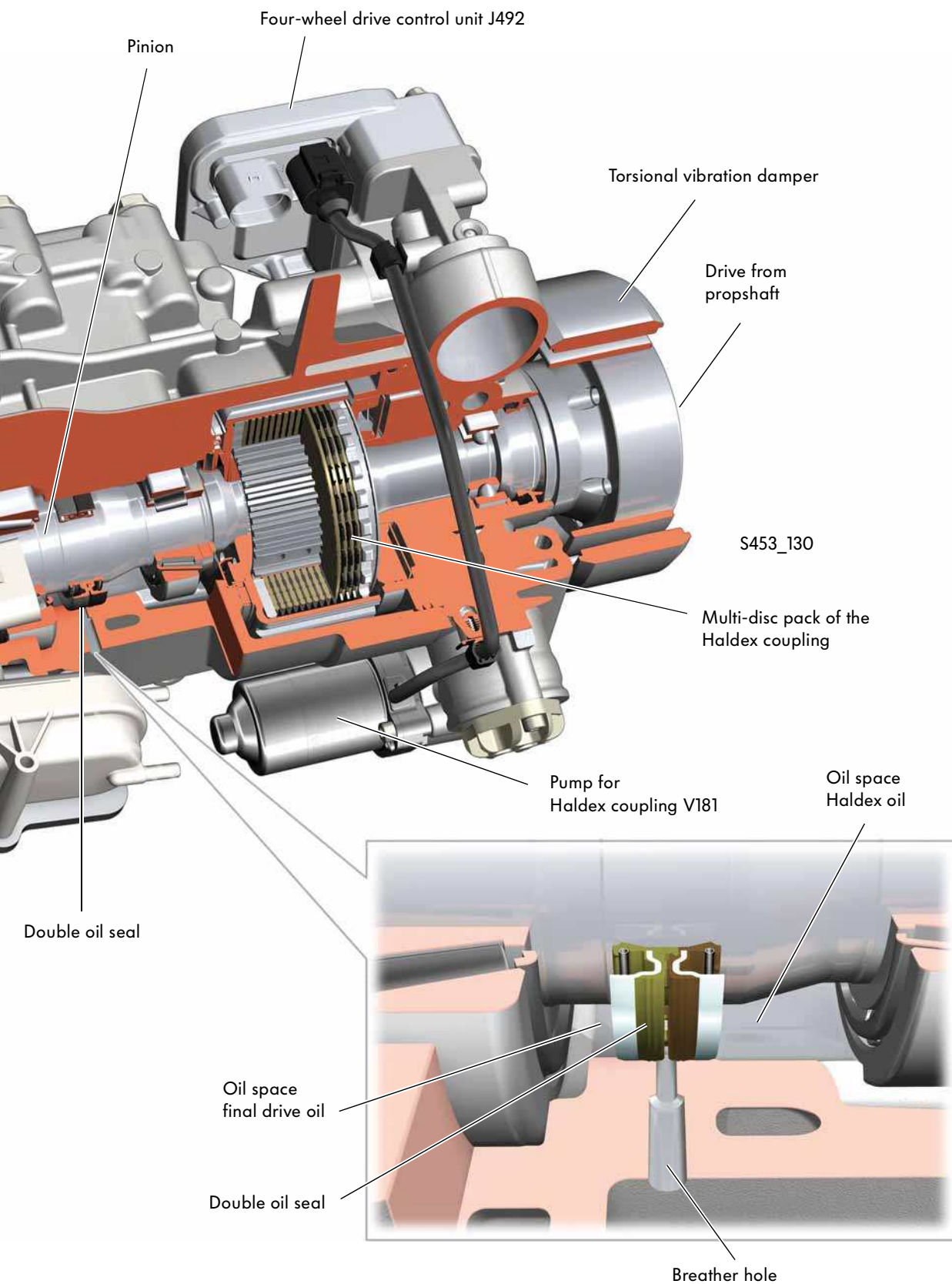



# Running gear

## Overview of the running gear

The basic structure of the running gear in the T5 2010 corresponds to that in the previous model.

Some important components of the running gear have undergone further development. This means it satisfies the demands of driving even more effectively.

- Revised ESP generation with extended range of functions
- Brake light switch and sender for clutch position in revised version

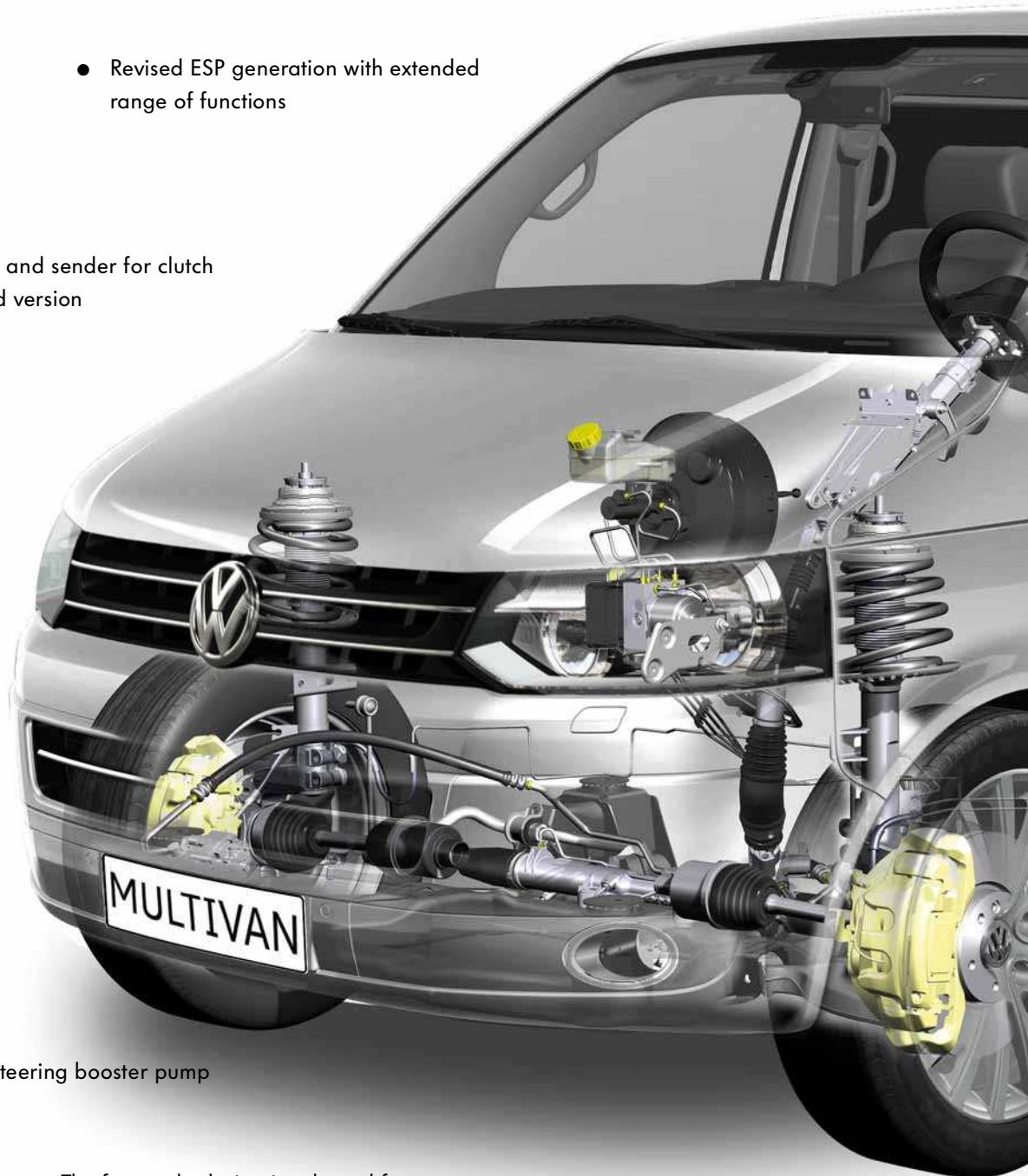

- Adjustable steering booster pump
- The front axle design is adopted from the Transporter 2004
- Servotronic steering with speed-dependent control



The picture corresponds to front-wheel drive.

- Four-wheel drive now also with the new 7-speed dual clutch gearbox OBT



S453\_076



- The rear axle design is adopted from the Transporter 2004

- New 17-inch dual piston brake on the front axle

# Running gear

## The brake system

### ESP system

From model year 2010 onwards, all T5 vehicles will receive the latest generation of ESP (electronic stabilisation programme). This is a further contribution towards the continuous process of meeting the safety targets set by Volkswagen Commercial Vehicles.

The ESP system is not available at present in back-to-back cabs (T5 cabs) intended for subsequent completion, e.g. as a mobile home, vehicle transporter or for manufacturing special vehicles.

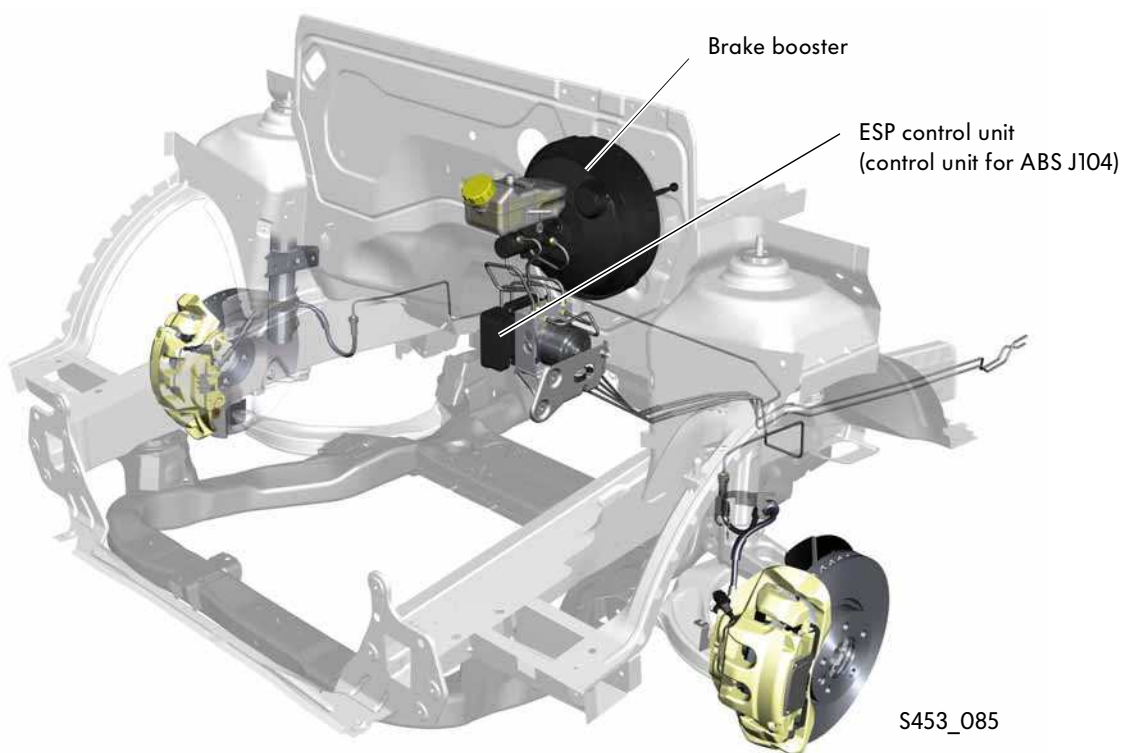

The ESP system MK 25 A-XT from Continental Teves is installed.

ESP (electronic stability programme) also combines the familiar functions:

- ABS (Anti-lock Brake System)
- EDS (electronic differential lock)
- TCS (Traction Control System)
- MSR (engine drag torque control)
- Hill hold assist

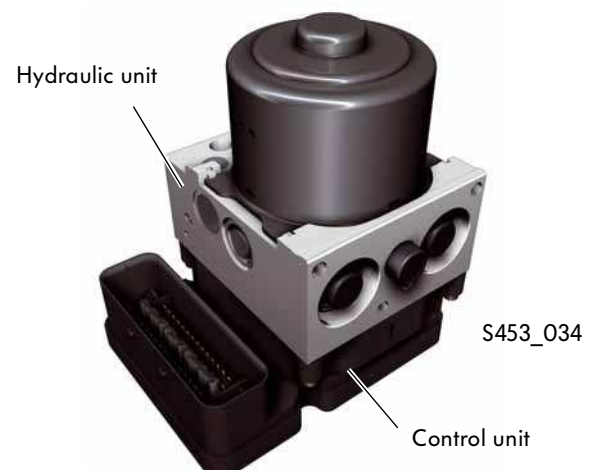

The system has the following new functions in addition to those already named:

Function	Functional description
<b>ARP (active rollover protection)</b>	<p>ARP minimises the risk of rolling over when cornering. If the transverse acceleration threshold value set for the individual vehicle is exceeded during cornering, the engine torque is reduced and the front wheel on the outside of the curve is braked. This reduces the rollover torque. Due to the large payload of the T5 2010, the vehicle load is generally included in the ARP control calculations.</p> <p>The control unit uses the longitudinal acceleration sender to register the current acceleration and uses the ratio between this and the engine torque, including the overall ratio, to calculate 3 different load conditions (unladen, half-laden and fully laden). Then, according to the load condition, the ESP control unit controls the optimum application point for ESP.</p>
<b>Maximum brake support</b>	Increased braking power (especially when vehicles are laden) during ABS control. When the front axle starts ABS-controlled braking, the brake pressure at the rear axle is increased until this also enters ABS-controlled braking.
<b>Ready alert brake (prefill)</b>	<p>If the foot is withdrawn rapidly from the accelerator pedal then it can be expected that emergency braking will follow.</p> <p>Therefore, in such situations, the brake pads are moved up into contact with the brake disc so that brake intervention can be more rapid, thereby reducing the braking distance.</p>
<b>Fading brake support</b>	If fading is detected (reduction in brake effectiveness when brakes are hot) then the brake pressure is increased using the ABS pump, thereby improving the braking effect.
<b>Hydraulic brake assistant</b>	The pneumatic brake assistant is replaced by a hydraulic brake assistant in the T5 2010. The brake assistant is activated when the driver presses the brake pedal quickly, but not powerfully enough. The system interprets this as panic braking, so the brake pressure is increased by the ABS pump until ABS control starts.
<b>Rain brake support</b>	As soon as the windscreen wipers are switched on, the brake pads are brought into contact briefly with the brake disc at regular intervals, thereby removing any film of water from the brake discs that may be present due to rain/splash water. This improves the responsiveness of the brake system in wet weather.
<b>Trailer stabilisation</b>	When driving with a trailer, trailer stability assist keeps the vehicle and the trailer on track. According to the requirements, individual wheels of the towing vehicle are braked or deceleration is initiated by reducing the engine torque. This means the vehicle/trailer combination is stabilised in case there is a risk of it becoming unstable. At present, this function is only possible if the trailer tow hitch is ordered as initial equipment.
<b>Tyre pressure monitor TPM</b>	The ESP control unit incorporates an indirectly measuring tyre pressure monitor for detecting a loss in tyre inflation pressure by evaluating the rolling circumferences of the wheels. If a tyre loses pressure, this is detected within a few minutes of driving by means of specific evaluation of the wheel speeds.



# Running gear

## Front brake

On its front axle, the T5 2010 has a 16-inch brake system.

The ventilated brake discs have the dimension  $\varnothing$  308 x 29.5 mm.

All T5 2010 vehicles with 132 kW engine or a gross vehicle weight rating of more than 3000 kg are equipped with new, revised 17-inch brakes on the front axle as standard.

The 17-inch brake is optional for all other engines.

The larger brake disc combined with the increase in pad contact area, improved pad pressure by a double piston calliper and more rigid housing thanks to the frame calliper principle mean that the braking effect is significantly improved, thereby increasing the performance of vehicle models with a 132 kW engine.

The ventilated brake discs have the dimension  $\varnothing$  340 x 32.5 mm.

16-inch front brake



S453\_082

17-inch dual piston front brake



S453\_083

## Rear brake

The rear axle of the T5 2010 is fitted with 16-inch brakes.

The ventilated brake discs have the dimension  $\varnothing$  294 x 22 mm.

16-inch rear brake



S453\_084

## Brake light switch on main brake cylinder

The mechanical switches on the pedal mechanism have been discontinued in all T5 2010 vehicles, and replaced by a brake light switch on the tandem main brake cylinder of the brake booster.

This brake light switch is one component that comprises two Hall sensors (to provide redundant backup).

The signals from both Hall sensors are sent to the engine control unit.

The brake light switch can be renewed individually.

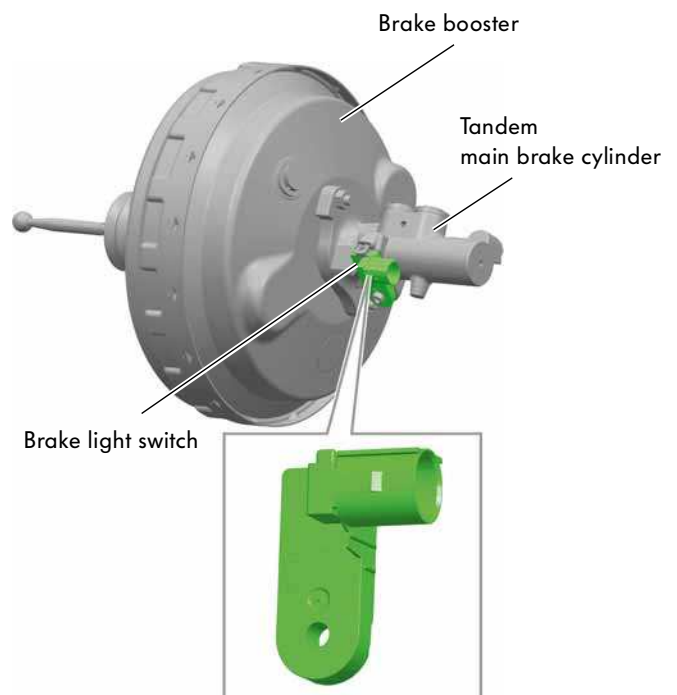

S453\_142



## Clutch position sender

Exclusively in the 132 kW engine version, a sender positioned on the clutch master cylinder is used for establishing the clutch position.

Two Hall sensors installed in the clutch position sender register when the clutch is actuated and also when the clutch pedal has been fully depressed.

The clutch position sender cannot be replaced individually.

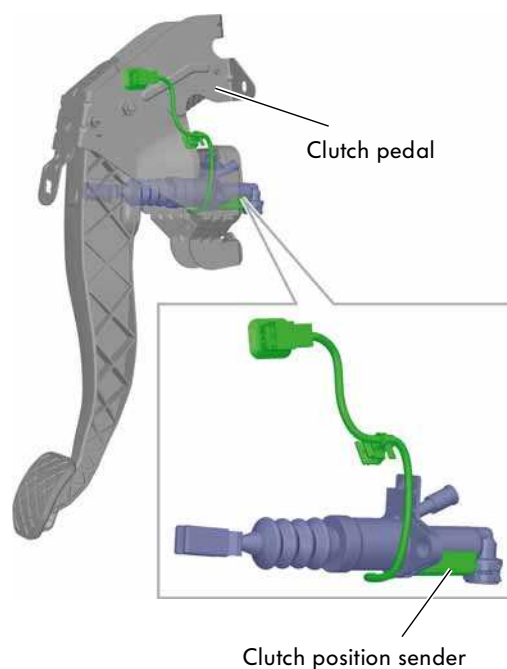

S453\_143



# Running gear

## The steering

All T5 2010 vehicles are equipped with hydraulic power steering.

Servotronic is available as standard for all Multivan Highline vehicles and is an option for all other T5 2010 models.

It is a feature of Servotronic that the steering support is reduced as the vehicle speed increases. This increases driving safety.

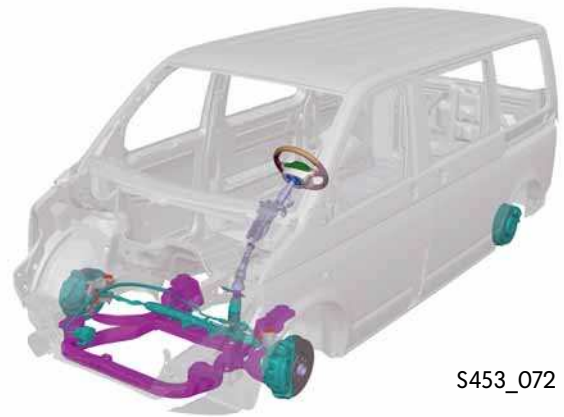

More details about Servotronic is available in self-study programme no. 277 "The Phaeton - running gear".

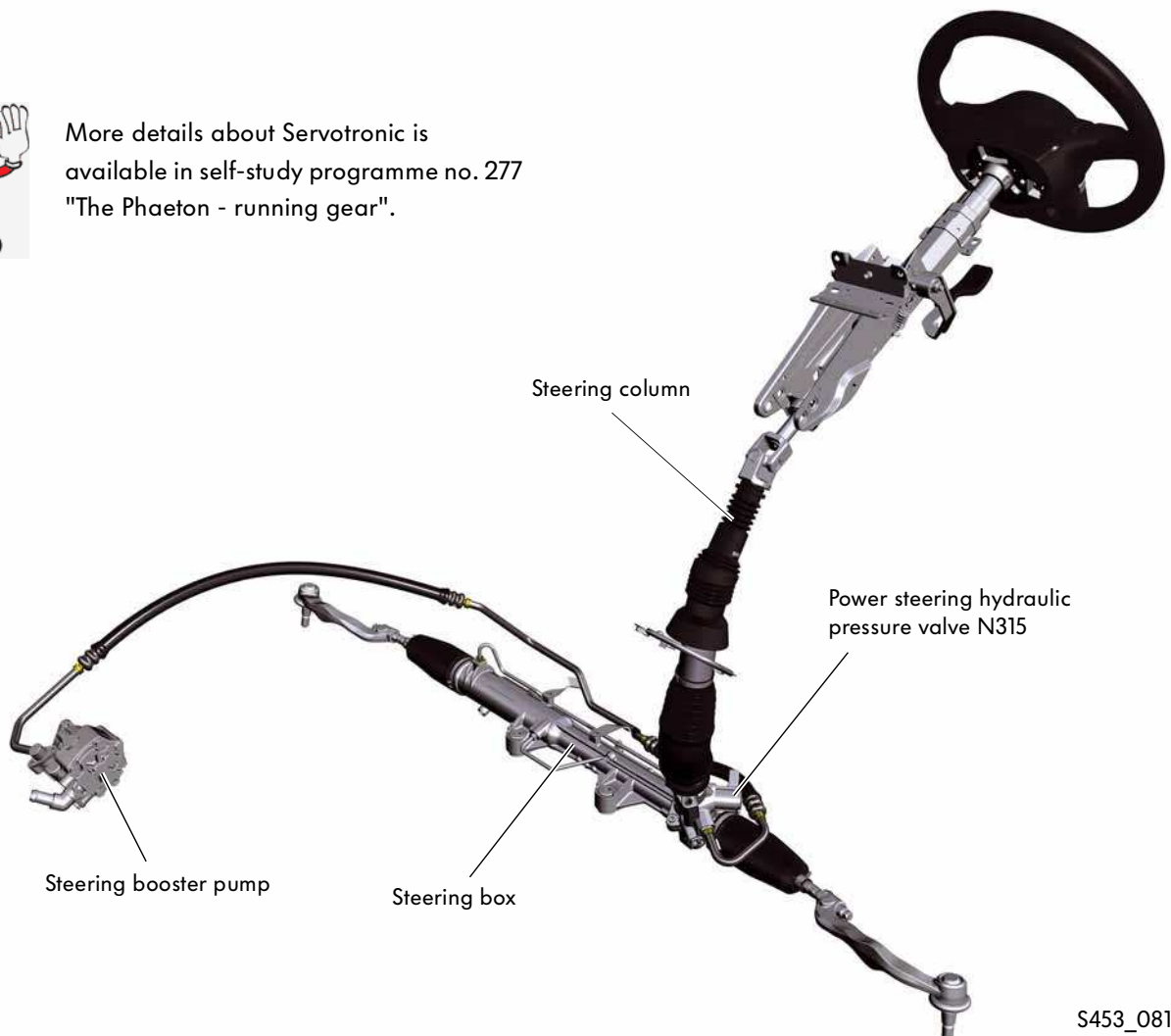

## Adjustable steering booster pump

The adjustable steering booster pump is mounted on the engine below the alternator, and is driven by the belt drive of the engine. It is used in all T5 2010 vehicles with a diesel engine.



### Structure and function

- The adjustable steering booster pump operates according to the functional principle of an adjustable radial piston pump.
- The pump has a cam disc, allowing the vanes to be adjusted.
- The delivery rate can be varied by the different positions of the vanes.
- The adjustment enables the pressure of the hydraulic pump to be adapted to the engine speed, thereby ensuring that the delivery pressure of the pump remains approximately constant.
- Advantage: This avoids any unnecessarily high power consumption by the hydraulic pump. As a result, fuel consumption is reduced.

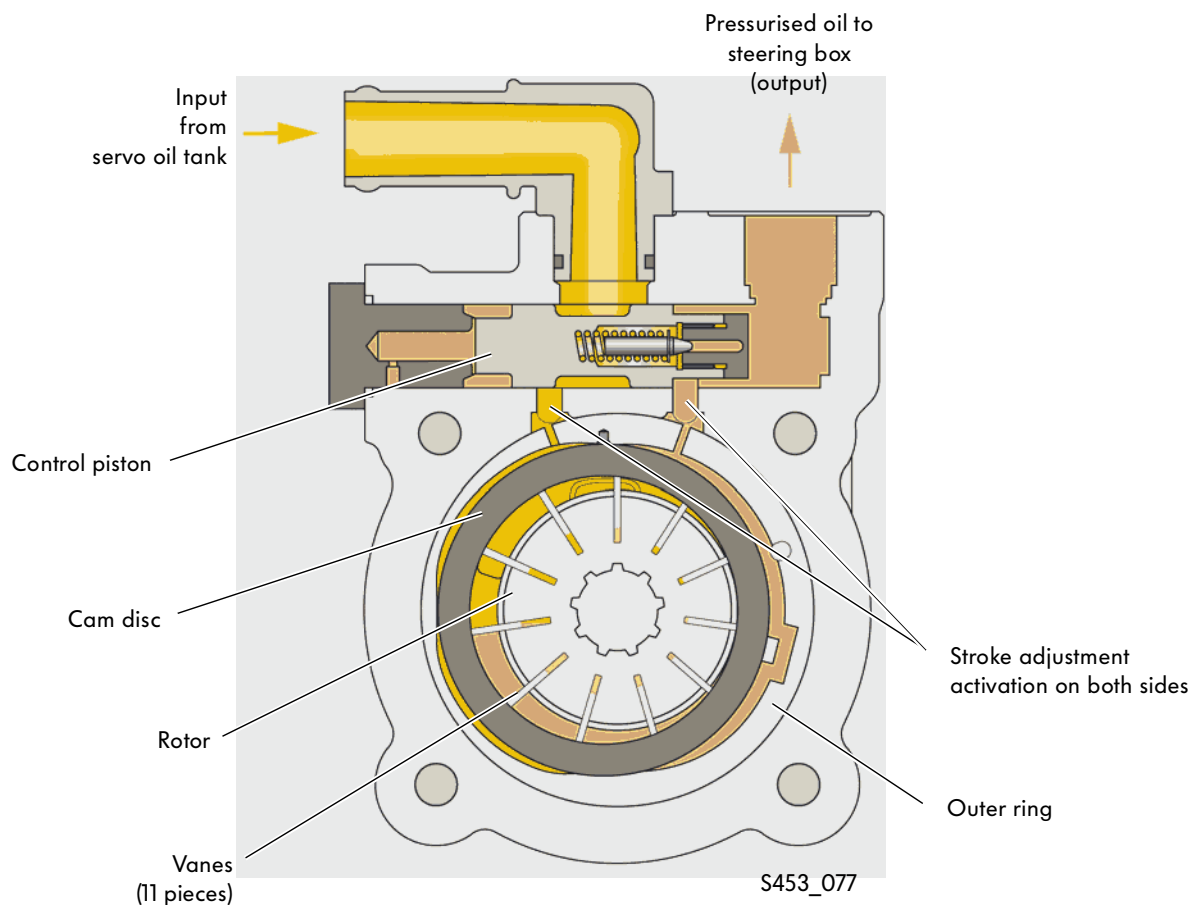

# Running gear

## Function

At idling speed ...

the cam ring of the pump is pressed against the outer ring by spring force and the internal pressure conditions. This produces the greatest possible delivery volumes on the suction and pressure sides. The delivery volume increases as the rotation speed increases, in proportion to the rotation speed.

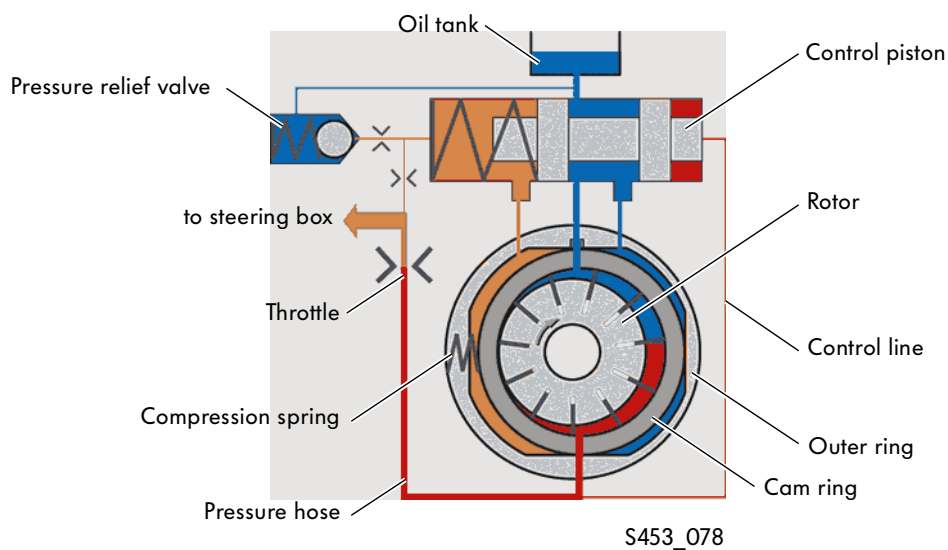

As the rotation speed rises ...

the pressure in the pump also increases. The pump pressure acts on one side of the control piston, and moves this to the left against the spring force as the pressure increases. In a defined medium rotation speed range, the ducts to the chambers between the outer ring and cam ring (left and right chambers) are closed by the control piston. This equalises the pressure between the two chambers. The cam ring is held in a defined central position, the delivery volume remains approximately constant.

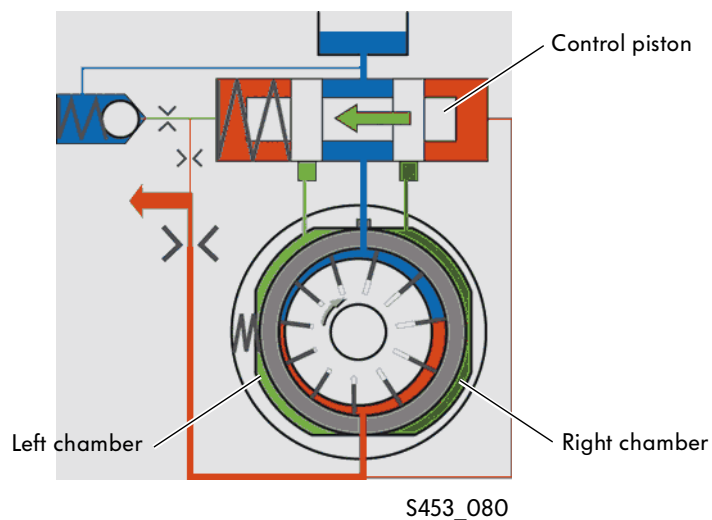

As the rotation speed increases further ...

The delivery volume and pressure increase if the rotation speed continues to rise. The control piston is pushed further to the left against the spring force, and therefore the duct to the left chamber is connected to the suction line. The opposite, right chamber has pump pressure applied to it. The cam ring is pushed to the left against the spring force - the eccentricity between the rotor and the cam ring is reduced. The delivery volume is reduced, thereby preventing "overproduction" of pressurised oil. The associated reduction in power consumption by the pump means that energy consumption is reduced significantly.

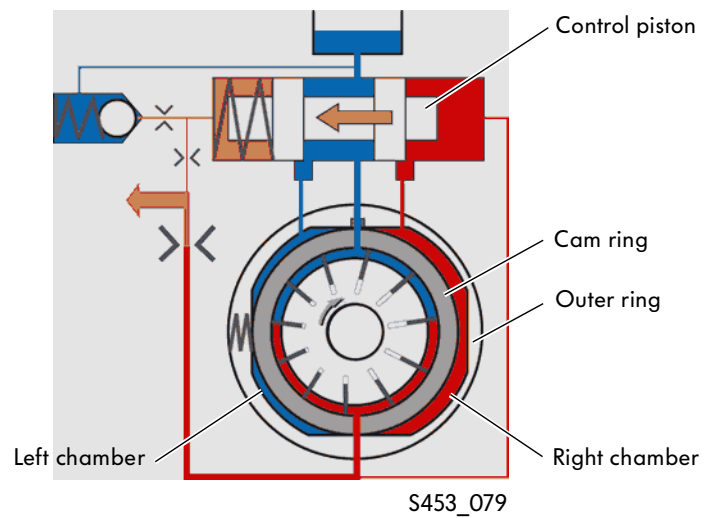

# Heating and air conditioning

## The climate control

The T5 2010 not only uses the manual heating and ventilation system but also the semiautomatic Climatic air conditioning system and the fully automatic Climatronic air conditioning system.

### Climatic

The Climatic replaces the manual air conditioning system familiar from the predecessor. The desired temperature is set on the electronic temperature dial, and this value is reached by adjustment of the temperature flap depending on the temperature conditions in the interior. The settings for the blower speed and air distribution are made manually on the relevant dials.

### Climatronic

The Climatronic enables all functions to be controlled fully automatically. Two different automatic modes are provided for the fresh air blower control. AUTO High mode is an automatic mode with optimum air quantities in order to counteract any possibility of fogging, and to achieve the desired temperature in the passenger compartment as soon as possible. AUTO Low mode is a mode with small air quantities. Acoustic comfort takes precedence. The temperature control is less abrupt, the fresh air blower speed is lower than in AUTO High mode.



### Side nozzles in comfort headlining

The T5 2010 with comfort headlining not only has nozzles for air-conditioning the compartment air, but also special side nozzles located further out from the normal nozzles. These side nozzles are used for blowing hot air over the side windows.

These nozzles make an effective contribution to keeping the side windows from fogging, or else make it possible to clear the side windows within a very short time.



Climatic control unit S453\_128



Climatronic control unit S453\_129

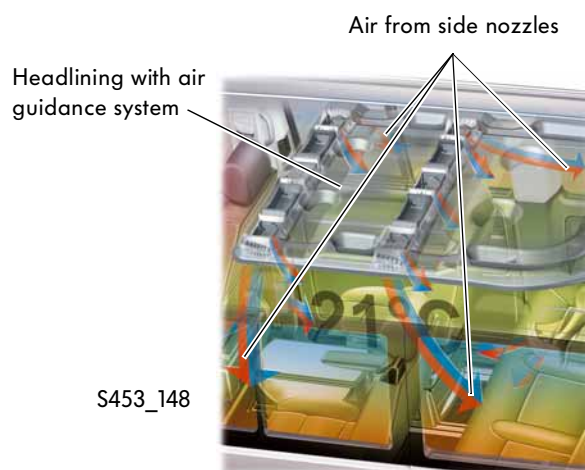

S453\_148



Nozzles in headlining - for air-conditioning the compartment air

Side nozzles

S453\_149



# The auxiliary heaters

The T5 2010 can be equipped with the following auxiliary heaters:

## Auxiliary heating

- Airtronic D3/B3 Plus auxiliary air heater (manufacturer: Eberspächer)
- Thermo Top C auxiliary water heater (manufacturer: Webasto)

## Supplementary heater

- Thermo Top Z auxiliary water heater (manufacturer: Webasto)

## Operating and display unit

The auxiliary heaters are operated by the operating and display unit for the auxiliary heater E407 in the roof - in the California, the auxiliary heater is operated using the operating and display unit for camping equipment E153.



S453\_126

Operating and display unit for auxiliary heater E407

## Airtronic auxiliary air heater D3/B3 Plus

The Airtronic D3/B3 Plus auxiliary heater is fitted in the T5 2010 in the same installation location as the replaced Air Top 3500 of the T5 2004.

The advantages of the Airtronic D3/B3 Plus are:

- More compact dimensions
- Lower weight
- Optimised and more precise control of the heating power levels



The basic structure and function of the Airtronic D3/B3 Plus corresponds to those of the Airtronic D2/D4S. For more information, refer to self-study programme no. 416 "Auxiliary heaters - part 2 Volkswagen Commercial Vehicles".

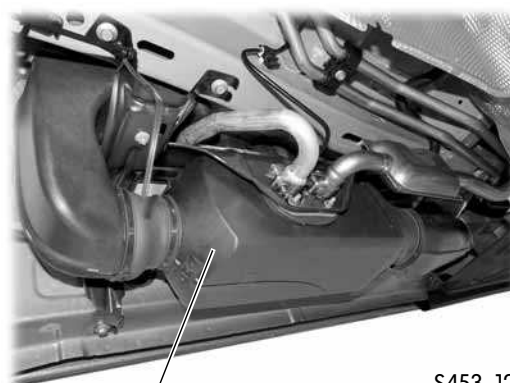

S453\_125

Auxiliary heater Airtronic D3/B3 Plus



## The installation locations of the control units

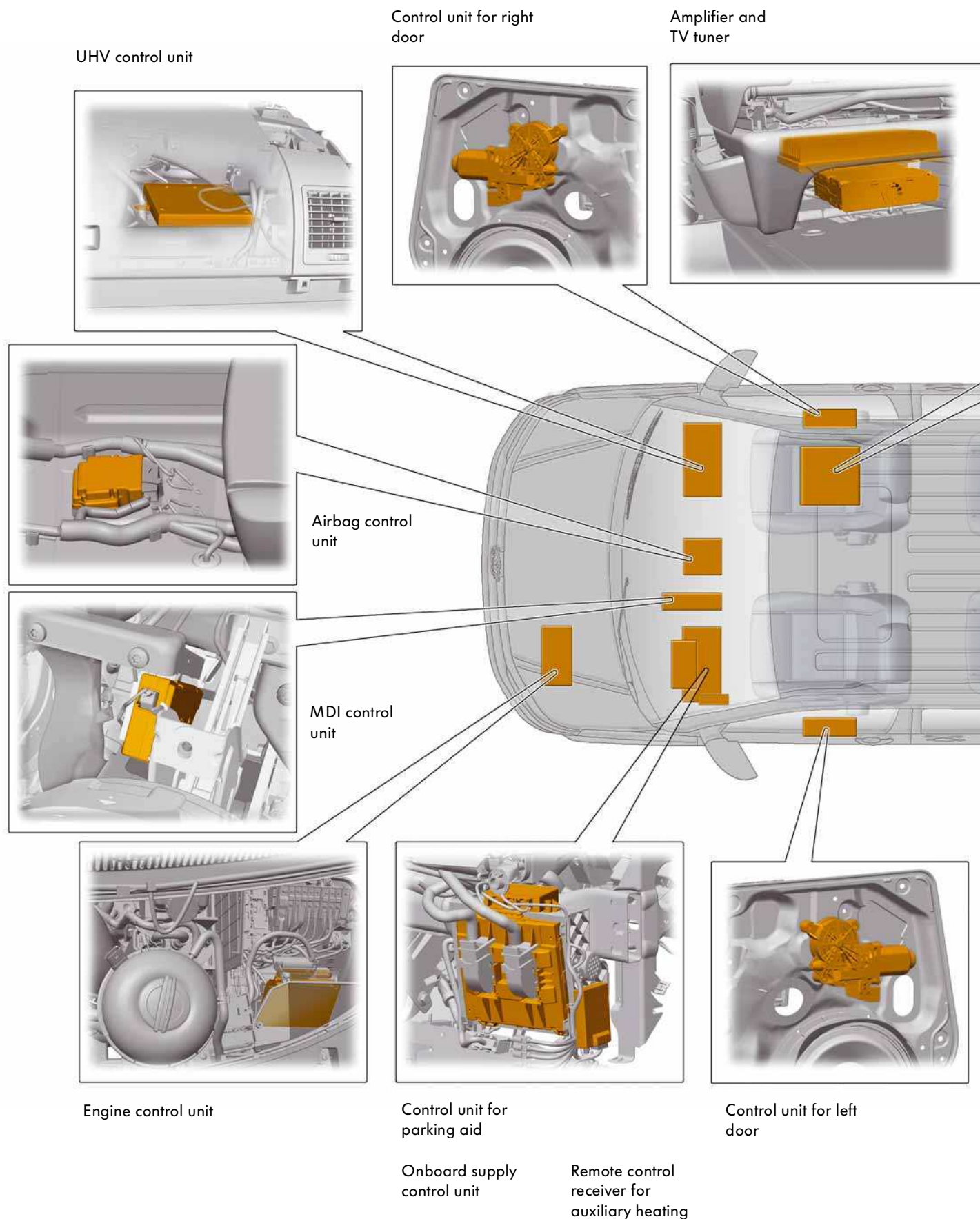

Control unit for voice amplification and CD changer

Control unit for trailer detection

Control unit for reversing camera

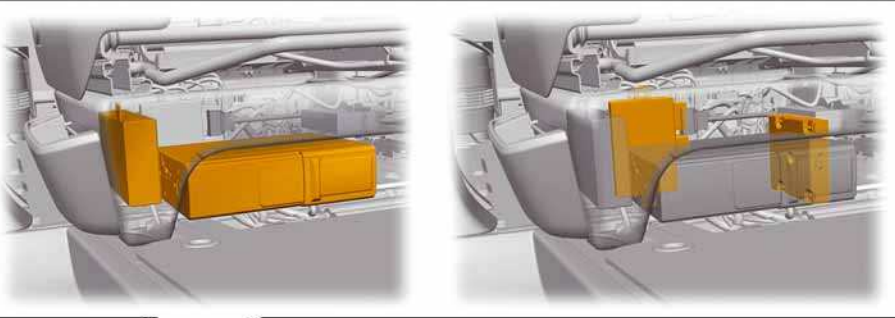

Control unit for lane change assist right

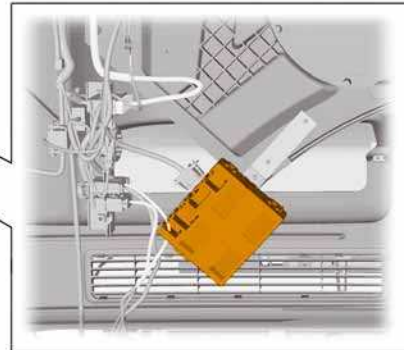
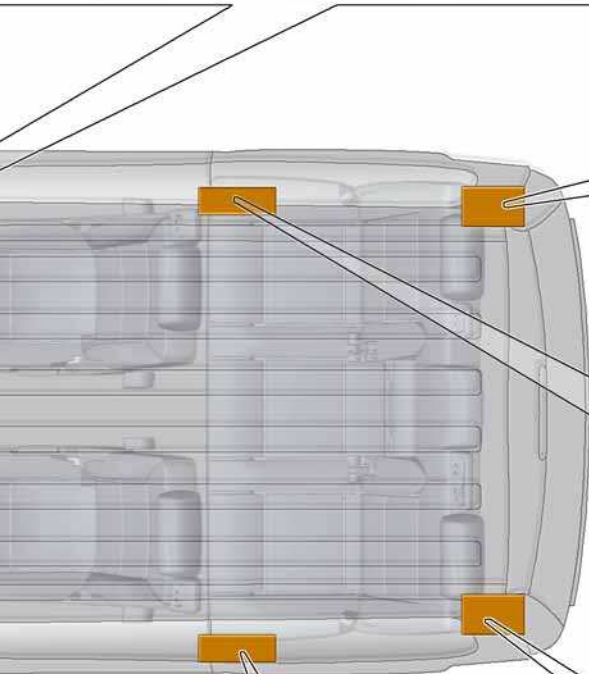
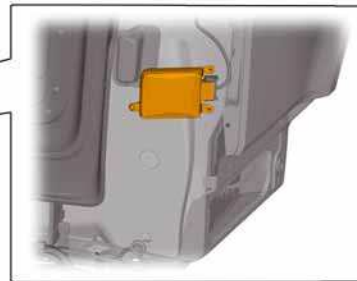

Control unit for right sliding door

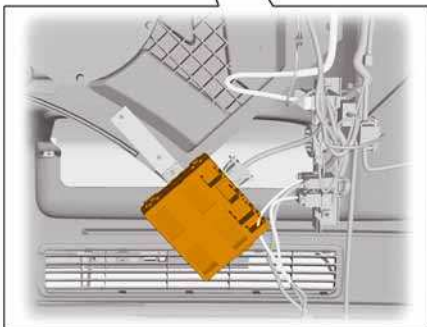

Left sliding door control unit

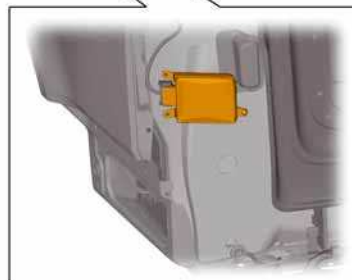

Control unit for lane change assist left

453\_089



## The networking concept

### What the abbreviations mean

- E265 Rear climate control unit
- E313 Selector lever
- G24 Tachograph
- G85 Steering angle sender
- G303 Interior monitor send and receive module 1
- G305 Interior monitor send and receive module 2
- G384 Vehicle inclination sender
- G397 Rain and light sensor
- G419 ESP sensor unit
- H12 Anti-theft alarm horn
- J104 ABS control unit
- J162 Water heater control unit
- J234 Airbag control unit
- J255 Climatronic control unit
- J285 Control unit in dash panel insert
- J345 Trailer detector control unit
- J362 Immobiliser control unit
- J364 Auxiliary air heater control unit
- J386 Driver door control unit
- J387 Front passenger door control unit
- J412 Mobile telephone operating electronics control unit
- J446 Parking aid control unit
- J492 Four-wheel drive control unit
- J503 Control unit with display for radio and navigation
- J519 Onboard supply control unit
- J527 Steering column electronics control unit in steering wheel
- J533 Data bus diagnostic interface
- J558 Left sliding door control unit
- J623 Engine control unit
- J656 Voice amplification control unit
- J702 Roof display unit
- J772 Reversing camera system control unit
- J731 Right sliding door control unit
- J743 Mechatronic unit for dual clutch gearbox
- J769 Lane change assist control unit
- J770 Lane change assist control unit 2
- J788 Isolator relay for CAN data bus drive
- R12 Amplifier
- R78 TV tuner
- R215 Interface for external multimedia devices
- T16 Diagnostic connection

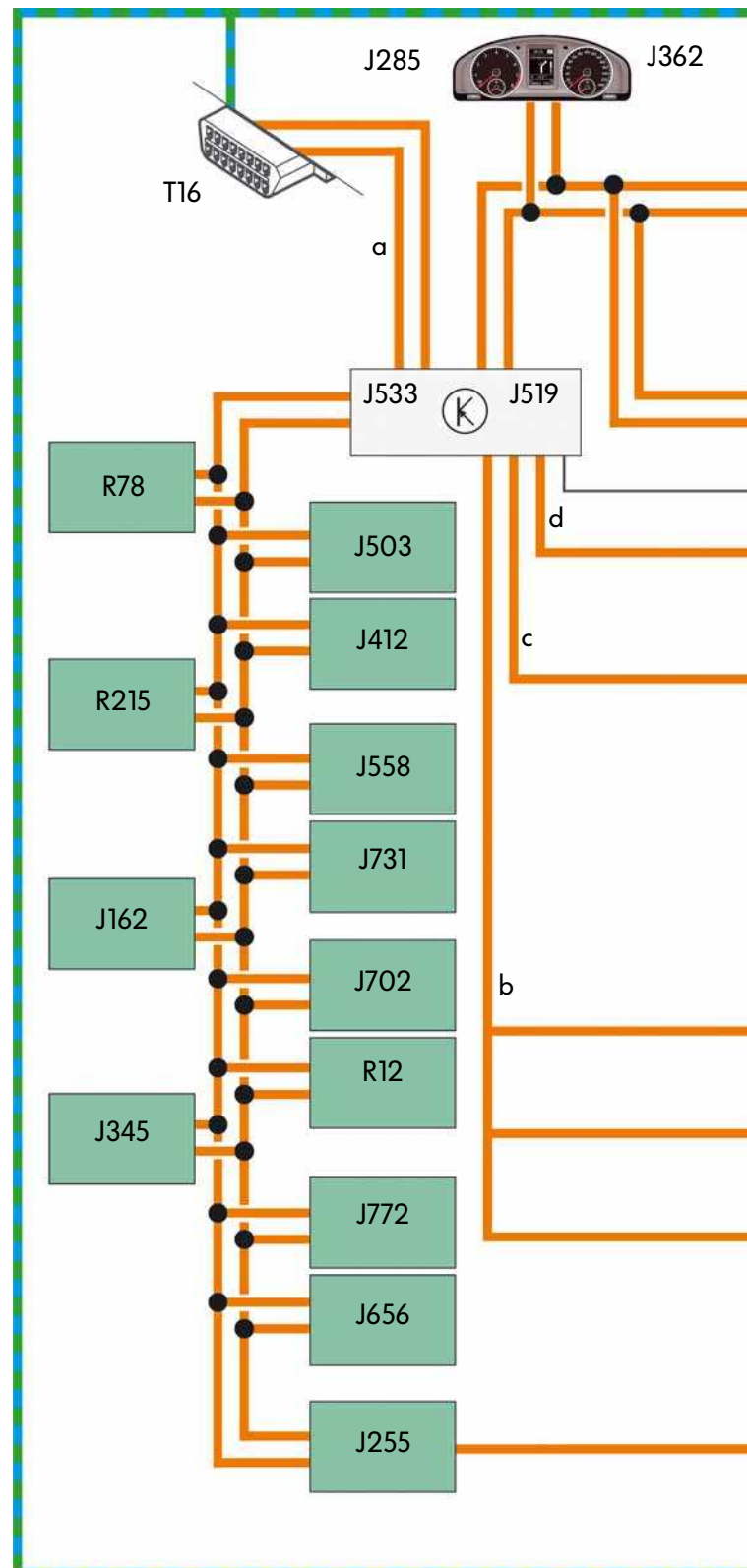

only for 2.0 l petrol engine

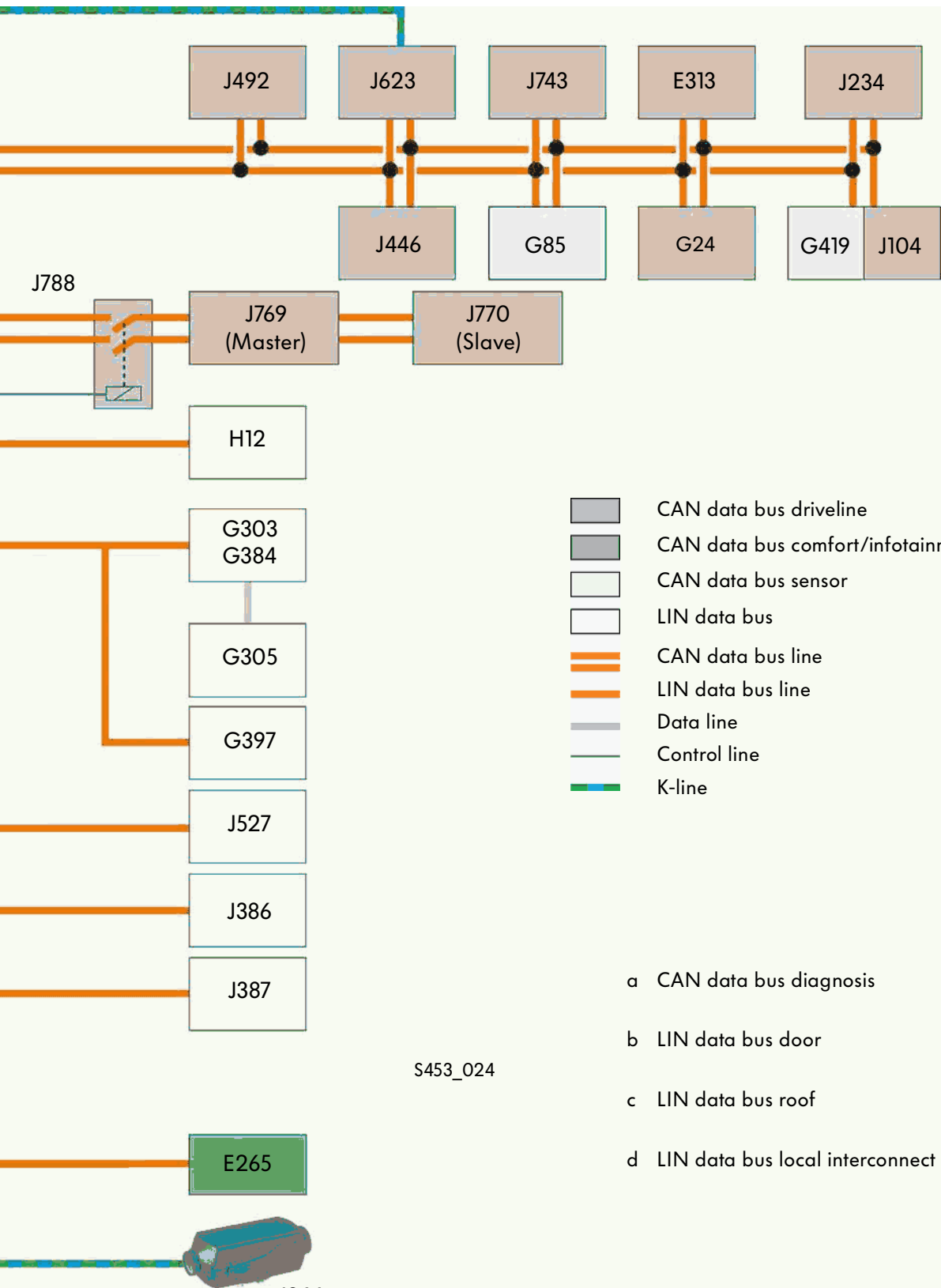

S453\_024

- a CAN data bus diagnosis
- b LIN data bus door
- c LIN data bus roof
- d LIN data bus local interconnect network



J364



## The onboard supply control unit J519

The new onboard supply control unit J519 in the T5 2010 has had various functions added to it. In contrast to the onboard supply control unit in the previous model, it now also handles the functions of the convenience system central control unit J393.

The onboard supply control unit J519 is connected to the onboard supply system via two 73-pin connectors.

Depending on the variant of the onboard supply control unit J519 (which varies in accordance with the vehicle equipment), it takes over the control of a wide variety of bulbs by means of integrated semiconductor switches. The particular bulb function is switched via one pin each in this case (e.g. all the turn signals on one side). Bulb monitoring has been implemented for the bulbs switched by the onboard supply control unit.

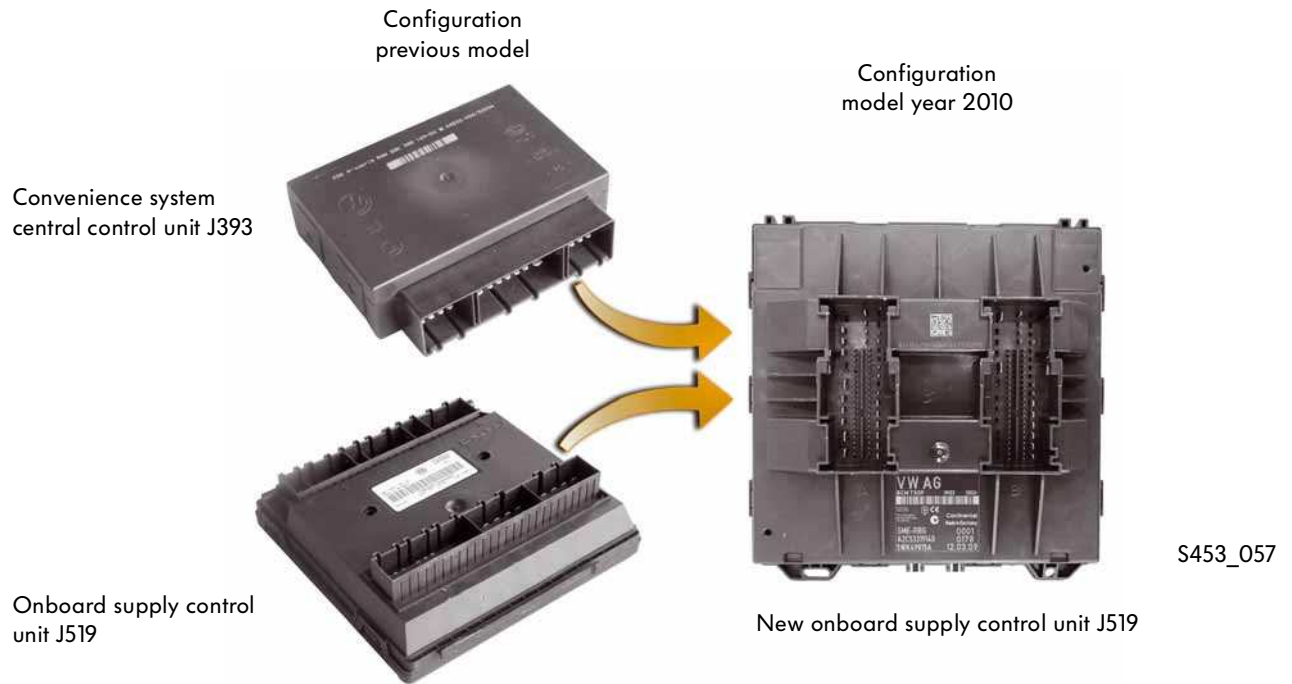

Depending on the control unit variant, the J519 controls at least the following external lighting functions and monitors them:

- Turn signal
- Side light/tail light
- Brake light

There are also bulbs that are switched via relays, e.g. main beam and headlight flash.

The aerial for radio remote control is integrated in the new onboard supply control unit. It is not configured as a wire aerial but rather as a printed circuit board aerial.

## Installation location

The onboard supply control unit is fitted in a bracket on the left under the dash panel.



The picture shows a view from the engine compartment through a cut-out opening in the bulkhead.

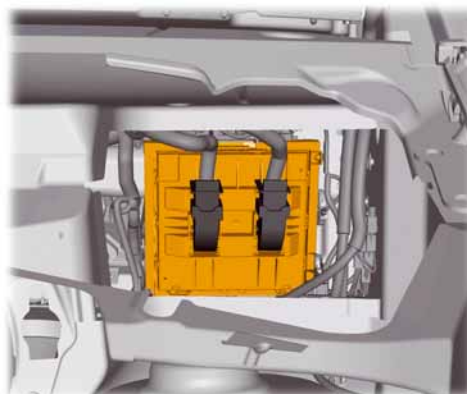

S453\_069

## Function

The range of functions depends on the equipment. More complex equipment extends the range of functions compared to the more straightforward equipment, as shown by the functions listed in the table.

The functions listed in the table include those functions that are used in the T5 2010 with its current equipment - the full range of possible functions of the onboard supply control unit is more extensive.

Control unit version	Range of functions of onboard supply control unit	
Medium ++	<ul style="list-style-type: none"> <li>- Load management</li> <li>- Control of electric fuel pump</li> <li>- Terminal control/terminal registration</li> <li>- Front and rear wiper control</li> <li>- Horn control</li> <li>- Battery isolation relay control</li> <li>- Heated rear window control</li> <li>- Heated exterior mirror control</li> <li>- Headlight washer system control</li> <li>- Interior light control</li> <li>- Brake light and turn signal/hazard warning light control</li> </ul>	<ul style="list-style-type: none"> <li>- Side light and parking light control</li> <li>- Seat heater and tilting/sliding sunroof enable</li> <li>- Central locking</li> <li>- Anti-theft alarm</li> <li>- Radio remote control (433 MHz)</li> <li>- Diagnostic interface for data bus</li> <li>- CAN diagnosis, driveline and convenience</li> <li>- LIN data bus door (driver and front passenger door, multifunction steering wheel)</li> <li>- LIN data bus roof (rain/light sensor, interior monitor/tilt sensor)</li> </ul>
High+	<ul style="list-style-type: none"> <li>- Shift lock and starter interlock</li> <li>- Reversing light control (DQ500 only)</li> <li>- Cruise control system</li> <li>- Fog light/static turning light control</li> <li>- LIN data bus anti-theft alarm (alarm horn)</li> </ul>	
Lights	<ul style="list-style-type: none"> <li>- Enable/read in main beam, light flash</li> <li>- Automatic running light, coming home, leaving home</li> <li>- Low beam, number plate light, daytime running light control</li> <li>- Rear fog light control</li> <li>- Reversing light control</li> <li>- Additional variant for radio remote control (315 MHz)</li> </ul>	



## The lights

### Headlights

The external design and also the interior structure of the chambers of the headlight unit have been adapted to Volkswagen's new style. As in the previous model, it has a clear glass structure and is installed in the two variants with H4 and H7 headlight module.

#### Headlight module H7

The T5 2010 is equipped with an H7 headlight model according to the model and equipment.

If there are no daytime running lights then only the 55 W coiled filament of the H15 bulb is used.



#### Headlight module H4

The T5 2010 is equipped with an H4 headlight model according to the model and equipment.

If there are no daytime running lights then the bulb for the daytime running lights is still fitted, but it cannot be used.

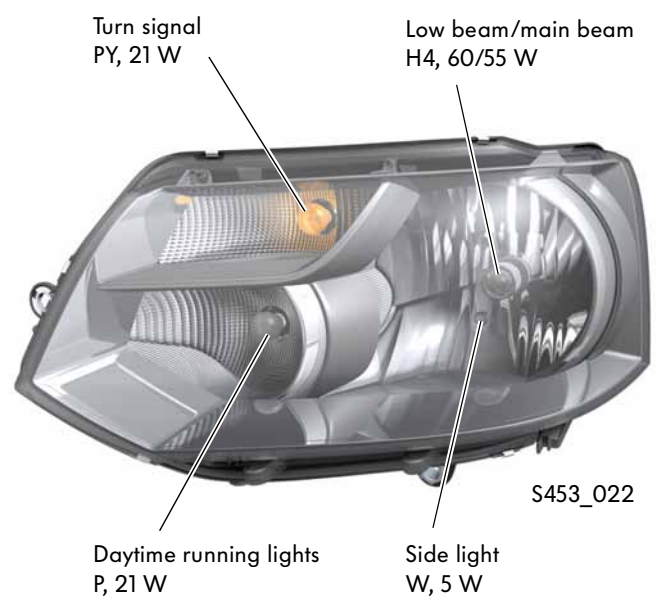

## Tail lights

The T5 2010 has two different tail lights.

In conjunction with the H7 headlight module, a new tail light is used which differs from the tail light in the previous model by its more striking design, its internal structure and the resulting distribution of the illuminated surfaces.

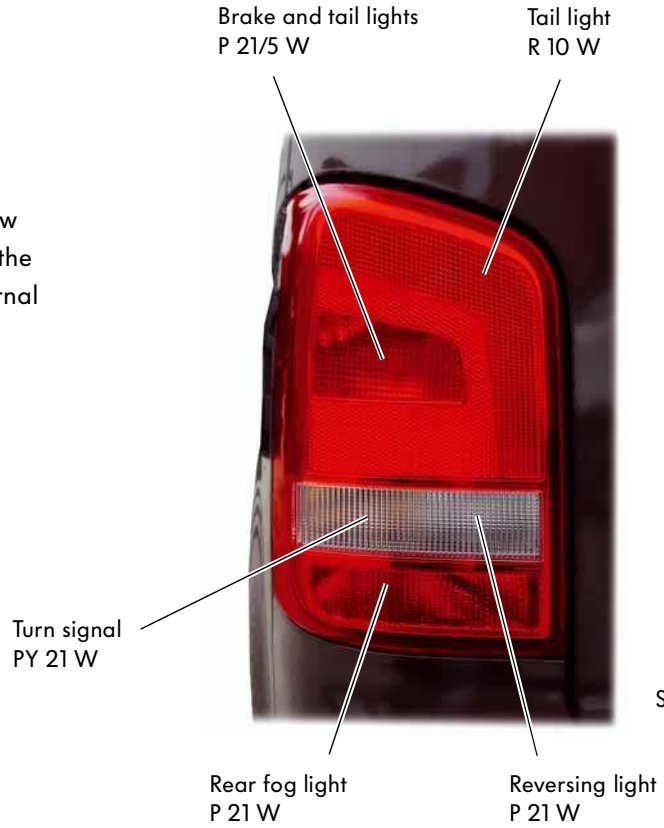

All other model variants of the T5 2010 retain the tail light familiar from the Multivan 2004, which is installed together with the H4 headlight module.

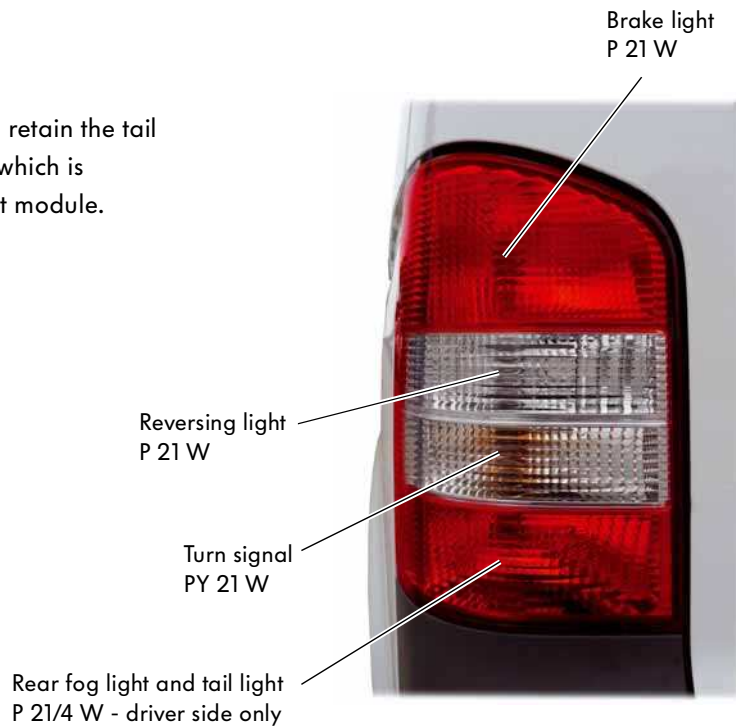

## Emergency brake display

All model variants of the T5 2010 now feature the new "emergency brake display" function.

The ABS control unit J104 detects an emergency braking situation based on the stored threshold values for deceleration and/or the ABS intervention time. It sets an emergency braking threshold if the speed is still faster than 60 km/h at this time. The onboard supply control unit controls the function of the emergency brake display in response.

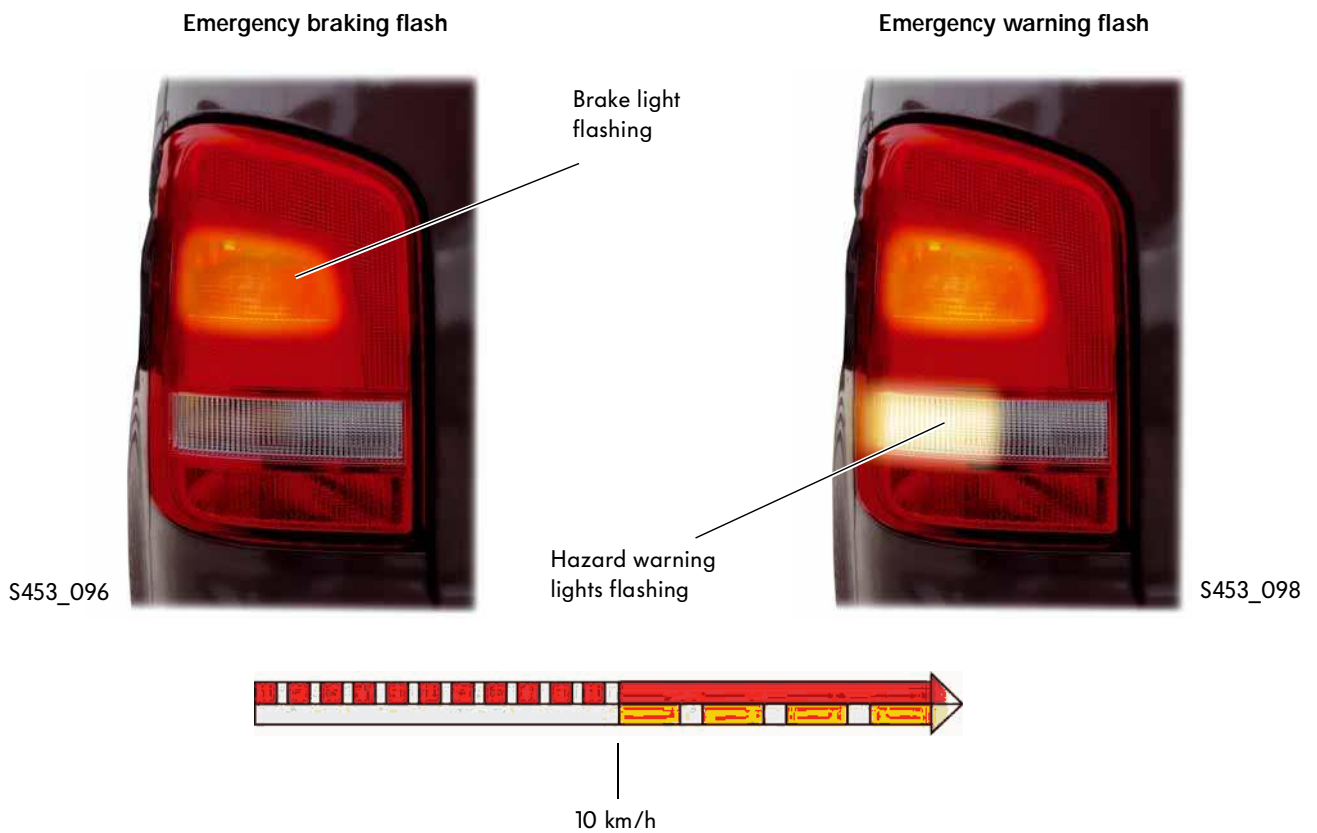

The emergency brake display is given in two stages.

- **Emergency braking flash** - When the vehicle is braked in a dangerous situation, the brake lights flash with high frequency as a warning to the traffic behind
- **Emergency warning flash** - If the speed drops below 10 km/h in this emergency braking situation then the brake lights stop flashing and reverts to a steady light for as long as the brake pedal is still being pressed. The hazard warning lights are switched on. The hazard warning lights are switched off automatically when the vehicle accelerates again and its speed exceeds 10 km/h

The hazard warning lights can also be switched off manually using the button on the dash panel



## Fog light - static turning light

If the T5 2010 is equipped with fog lights then these are also used for the function of the static turning light.



The static turning light is switched on by the onboard supply control unit J519 in accordance with the vehicle speed, the steering wheel angle and the turning request.

The turn indicator signal has a greater priority than the steering angle in this case. For example, if the onboard supply control unit receives the information "turn indicator = left" and "steering wheel angle = right" then the direction of the indicators applies.

At speeds up to 40 km/h, the side of the road on the inside of the bend is illuminated by the fog light when the vehicle is turning. The light is switched on and off with a dimming function.



## The lane change assist

The T5 2010 (closed bodies, short wheelbase and tailgate) is now available with lane change assist (Side Assist) as an option.

The lane change assist warns the driver about vehicles that are located to the side in the "blind spot" or which are approaching rapidly from behind. To achieve this, two radar sensors scan the adjacent lanes on either side, both to the side and to the rear of the vehicle. If the lane change assist detects a critical situation, the warning light for the lane change assist (LED system) in the exterior mirror housing on the side of the vehicle in question indicates that there is a risk. The system can be switched on and off using a switch in the centre dash panel or using the multifunction indicator. The system automatically switches to active mode at a speed of 30 km/h or more.

The lane change assist warning lamp in the right-hand round instrument of the dash panel insert indicates whether the system is active or passive.

Functions of warning lamp ...

- ... not lit - system is switched off or there is an error
- ... yellow - system switched on and passive
- ... green - system switched on and active

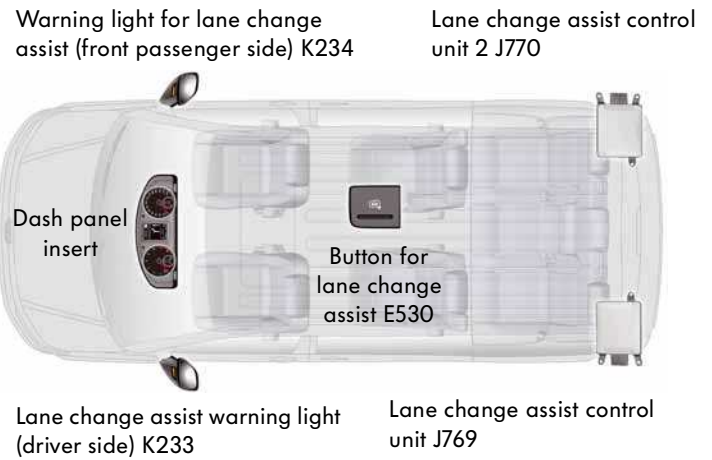

S453\_071

Warning light for lane change assist K232 - function of light ...

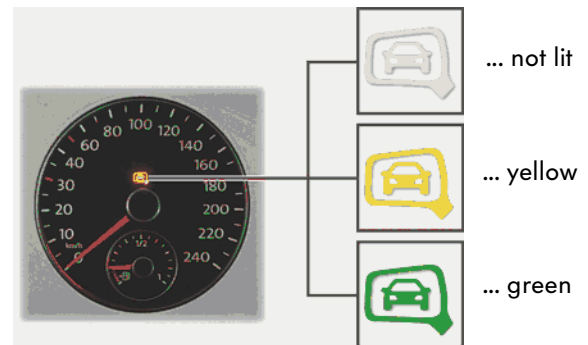

S453\_110



## Installation position of the control units

The lane change assist control units are each installed behind the cover under the tail light. The sensors are also integrated in these control units.



For information about the lane change assist, refer to self-study programme no. 396 "The lane change assist"

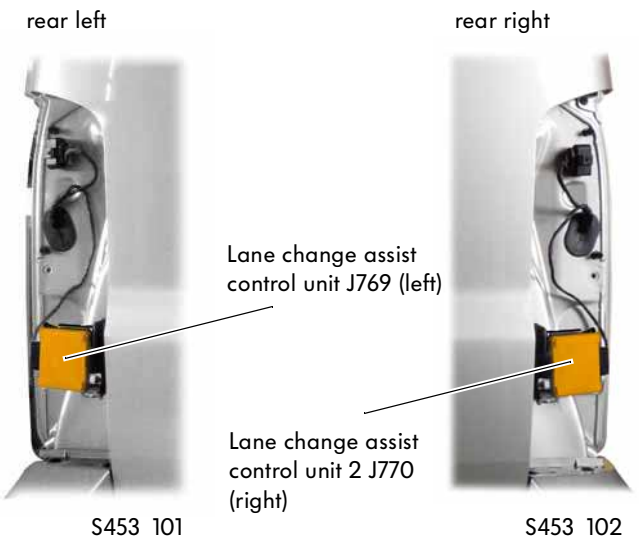

# The reversing camera system

As an extension to the previous, ultrasound-based system for assistance during parking, the T5 2010 with tailgate can be equipped with the option of a reversing camera system.

The reversing camera system operates with a wide-angle camera in conjunction with a control unit. The camera is fitted in the number plate light.

In the dark, the illumination in the rear area of the vehicle provided by the reversing light is sufficient to allow perfect function.

The field of view to the rear that can be observed via the camera is transferred to the control unit installed in the right seat box and is processed there so that it can be displayed on the colour display of the navigation system without distortion and with superimposed dynamic and static assistance lines.



Detailed information about the reversing camera system is available in self-study programme no. 407 "The reversing camera system".

## Installation position of system components

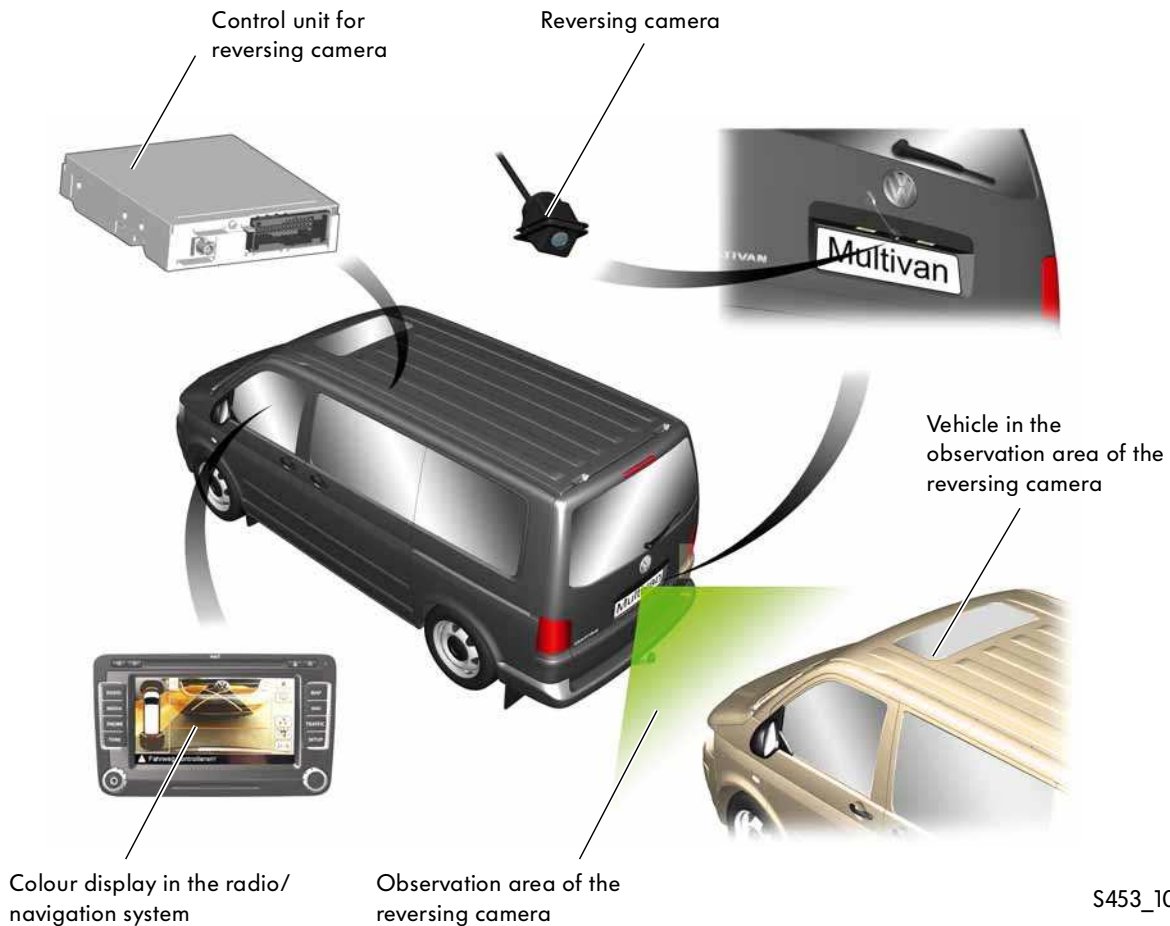

## The dash panel

The dash panel has been revised for the T5 2010. Overview of new features: revised lines, surfaces, newly designed dash panel inserts, completely new radio/navigation range and updated controls for heating/ventilation and air conditioning systems.

The joystick control in the dash panel has been retained.

Two different equipment versions of the dash panel are installed:

Some models like the Caravelle and platform vans have the dash panel shown adjacent.

The middle section of the dash panel only has a narrow downwardly tapering housing contour for accommodating the joystick control.



S453\_009

Other models, such as the Multivan Highline, feature the following dash panel.

This dash panel version is extended downwards in the centre part across the full width of the display units located above, for the purpose of accommodating the joystick control and for accommodating other controls and storage possibilities.



S453\_008

## Dash panel insert

Three variants of the dash panel insert are fitted in the T5 2010 depending on the vehicle equipment.

Standard



S453\_086

Medium



S453\_133

Premium



S453\_134

## Gearshift recommendation

Depending on the equipment, the T5 2010 has a display in the multifunction indicator of the dash panel insert in order to provide a recommendation for the driver to change gear in order to drive more economically.

- Arrow = Gearshift recommendation – lower/higher gear
- Number = Target gear
- Dot = No gearshift recommendation given  
(the digit next to the dot shows the currently engaged gear that corresponds to the optimum engine revs)

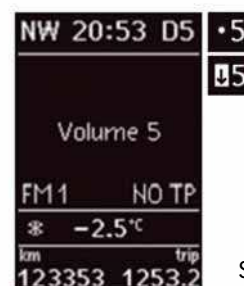

S453\_144

In vehicles with DSG, the engaged drive range and the current gear are displayed.

## The media device interface box

The T5 2010 is optionally equipped with the media device interface box (MDI box). It makes it possible to connect portable audio and memory devices and to play back their audio files via the radio or navigation system.

The media device interface box is fitted on the right above the pedals. The connection socket installed in the glove compartment is used for connecting portable devices.

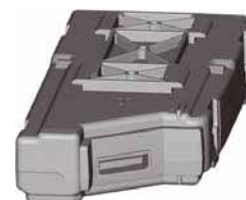

S453\_140



Detailed information about the media device interface box can be found in self-study programme no. 423 "The Golf 2009".





# Radio, phone and navigation

## The radios and radio navigation systems

<p><b>Technical data</b></p>	 <p>RCD 210 <span style="float: right;">S453_061</span></p>	
<p>Monochrome display</p>	<p>122 x 36 pixels</p>	
<p>Colour display, touchscreen</p>		
<p>FM, TP and RDS reception (single tuner)</p>	<p>●</p>	
<p>FM twin tuner for FM, TP and RDS reception with phase diversity</p>		
<p>AM reception</p>	<p>●</p>	
<p>Integrated DAB tuner (digital radio)</p>		
<p>Radio Data System (RDS)</p>	<p>●</p>	
<p>TMC function and TMC background reception</p>		
<p>Voice control</p>		
<p>Integrated CD player</p>	<p>●</p>	
<p>Integrated SD memory card reader</p>		
<p>Media support</p>	<p>CD and MP3 audio data</p>	
<p>Audio input interface (AUX-IN)</p>	<p>●</p>	
<p>Telephone interface for telephone hands-free device</p>	<p>● (mono channel only)</p>	
<p>Interface for connecting a reversing camera</p>		
<p>Loudspeaker output stages with 20 watt output (2 or 4 loudspeakers can be connected)</p>	<p>●</p>	
<p>Treble, bass and balance adjustment</p>	<p>●</p>	
<p>Fader setting (only with four loudspeakers)</p>	<p>●</p>	
<p>Speed dependent volume adjustment</p>	<p>●</p>	
<p>Brightness of display lighting can be controlled independently from lighting inside vehicle</p>	<p>●</p>	
<p>Self-diagnosis and loudspeaker diagnosis</p>	<p>●</p>	
<p>Service test mode</p>	<p>●</p>	
<p>Navigation function with map, integrated driving symbols and speech</p>		
<p>DVD/SD navigation</p>		
<p>DVD/HDD navigation</p>		
<p>For more information, see self-study programme</p>	<p>no. 404</p>	



For information about the abbreviations used with the radios and radio/navigation systems, please refer to self-study programme no. 423 "The Golf 2009".

 <p><b>RCD 310</b> S453_059</p>	 <p><b>RNS 310</b> S453_060</p>	 <p><b>RNS 510</b> S453_058</p>
302 x 45 pixels	5.5-inch, 400 x 240 pixels	6.5-inch, 800 x 480 pixels
●	●	●
●	●	●
depending on equipment		
●	●	●
	●	●
		●
●	●	● (DVD player)
	●	●
CD, MP3 and WMA audio data	CD, MP3 and WMA audio data, navigation data	CD, MP3 and WMA audio and DVD video data, navigation data
●	●	●
●	●	●
		●
●	●	●
●	●	●
●	●	●
●	●	●
●	●	●
●	●	●
	●	●
	Map view (3D)	Map view (2D and 3D)
	●	
		●
No. 417	No. 423	No. 423



# Radio, phone and navigation

## The aerial concept

The T5 2010 has a complete aerial system for radio, TV, phone and GPS integrated in the exterior mirrors. The mirrors are configured as module exterior mirrors or exterior mirrors on extension bars depending on the model variant.

### Module exterior mirrors for closed bodies

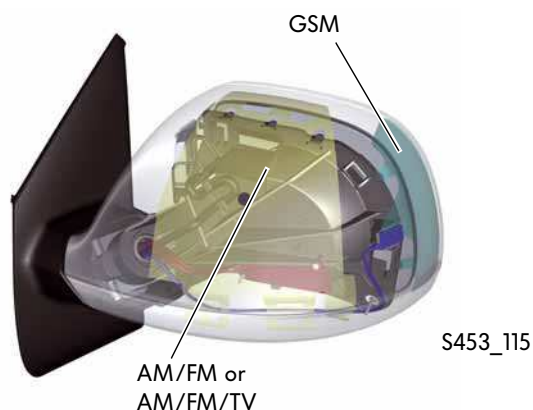
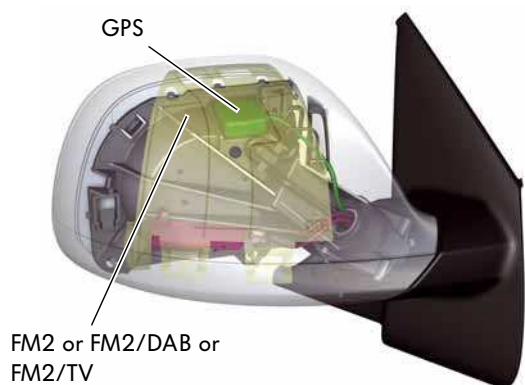

#### Right exterior mirror

The signal pathways of the FM2 or FM2/DAB or FM2/TV aeriels are located on a shared aerial foil in each case. The GPS aerial is attached to the interior housing of the exterior mirror.

#### Left exterior mirror

The AM/FM or AM/FM/TV aeriels are each located together on one aerial foil with associated signal pathways. The GSM aerial is located on a separate aerial foil.

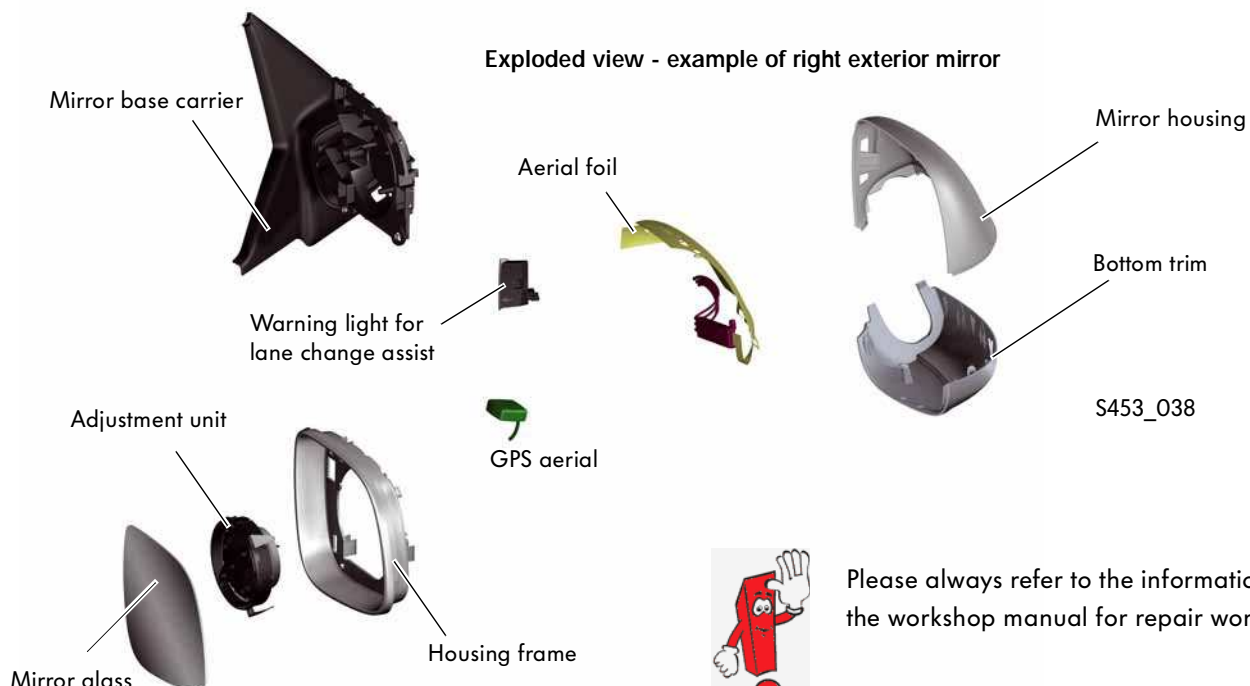

Please always refer to the information in the workshop manual for repair work.

## Exterior mirror on extension bars for open bodies

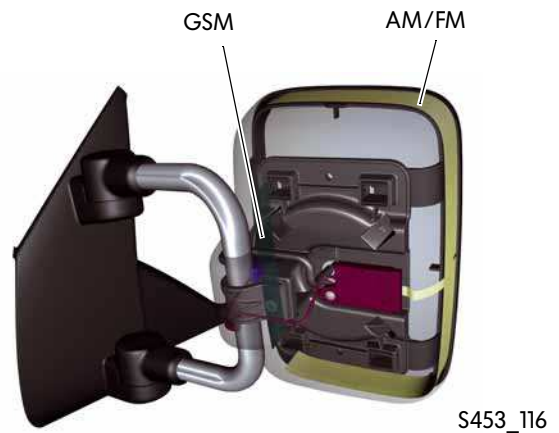
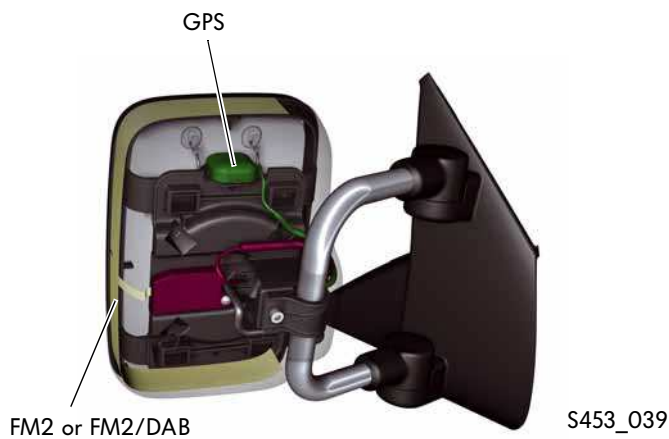

### Right exterior mirror

The signal pathways of the FM2 or FM2/DAB aeriels are located on a shared aerial foil in each case. The GPS aerial is attached to the interior housing of the exterior mirror. At the moment, no TV aerial is provided.

### Left exterior mirror

The AM/FM aerial is located on an aerial foil with associated signal pathways. The GSM aerial is located on a separate aerial foil on the inside of the mirror housing.

### Exploded view - example of right exterior mirror



# Radio, phone and navigation

## Aerial assignment - module exterior mirror

Each of the aerial combinations shown in the picture is possible for the module exterior mirrors.



## Mirror aerials

### AM, FM, DAB, TV aerial with impedance converter

Aerial foils, impedance converter and aerial cables are grouped into one component and cannot be renewed separately.

AM, FM, DAB and TV aerials are phantom powered. The phantom supply (approx. 12 V) is used for supplying power to the impedance converter and the diagnostic function.

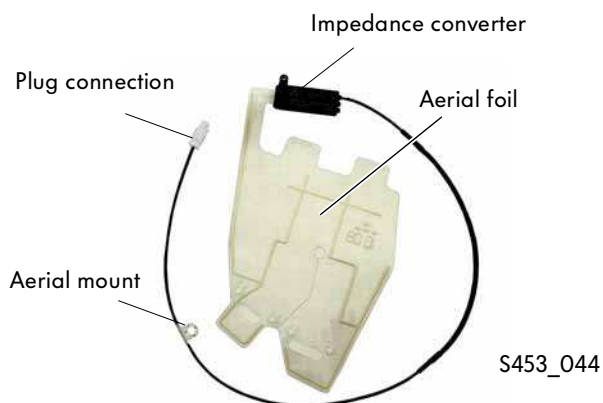

The illustration above shows an FM2 aerial by way of example.

### GPS aerial

The GPS aerial is secured with an adhesive pad. The internal electronics are powered via the phantom supply (5 V).



### GSM aerial

In the GSM aerial, the phantom supply (12 V) is only required for the diagnostic capability.

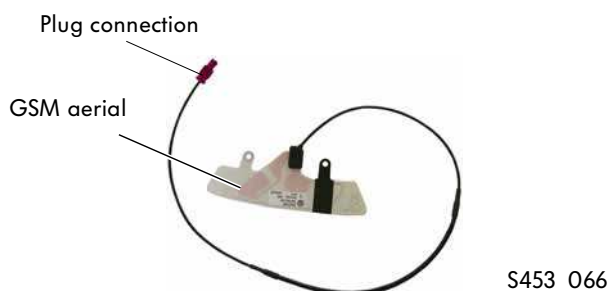

All aerials can be renewed separately. The plug connections are mechanical and colour coded.





## Aerial assignment - exterior mirror on extension bars

Each of the aerial combinations shown in the picture are possible for the exterior mirrors on extension bars.



## Mirror aeriels

### AM, FM, DAB aerial with impedance converter

Aerial foils, impedance converter and associated cables form one component. The exterior mirror can be dismantled without damaging it.

The aerial foils are attached in the exterior mirror by glue points.

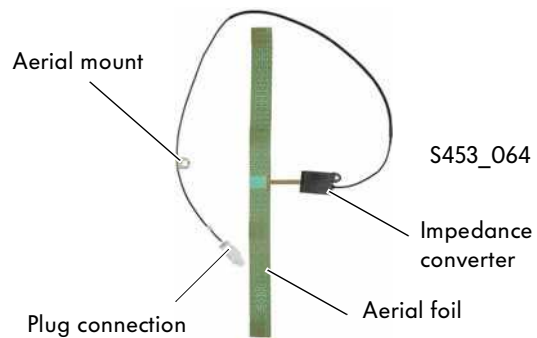

### GPS aerial

The GPS aerial is located on a magnetic holder. This is screwed onto the inside of the mirror housing. All plug connections are mechanical and colour coded.

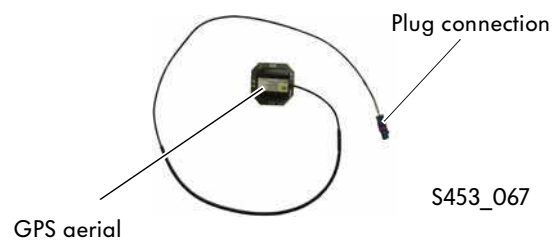

### GSM aerial

The GSM aerial is attached to the inside of the mirror housing by glue.

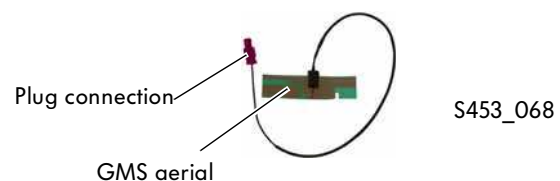

Regarding the phantom supply and diagnostic capability, please refer to the module exterior mirror.



# Radio, phone and navigation

## Aerial - onboard power supply connection

The AM, FM, TV and DAB aerials need antenna mounts that are located inside the doors. To ensure a perfect earth connection to the doors, the doors have an earth connection to the body earth via a separate earth cable.

Interference in the AM reception area is minimised in accordance with the vehicle equipment by installing an AM filter for all electrical connections to components that are located inside the exterior mirror (exterior mirror heater, adjustment, etc.). The AM filter is part of the door cable kit.

The AM aerial is always located in the left exterior mirror, therefore no filter is required on the right side.



S453\_141

## Aerials - radio preparation

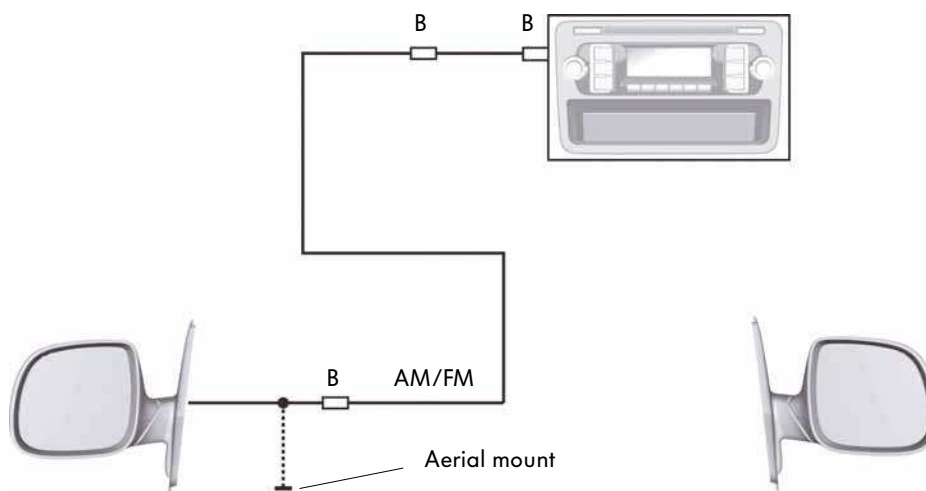

S453\_050

Left exterior mirror

Right exterior mirror

- AM/FM aerial

- without aerials



## Aerials - radio RCD 210 and UHV

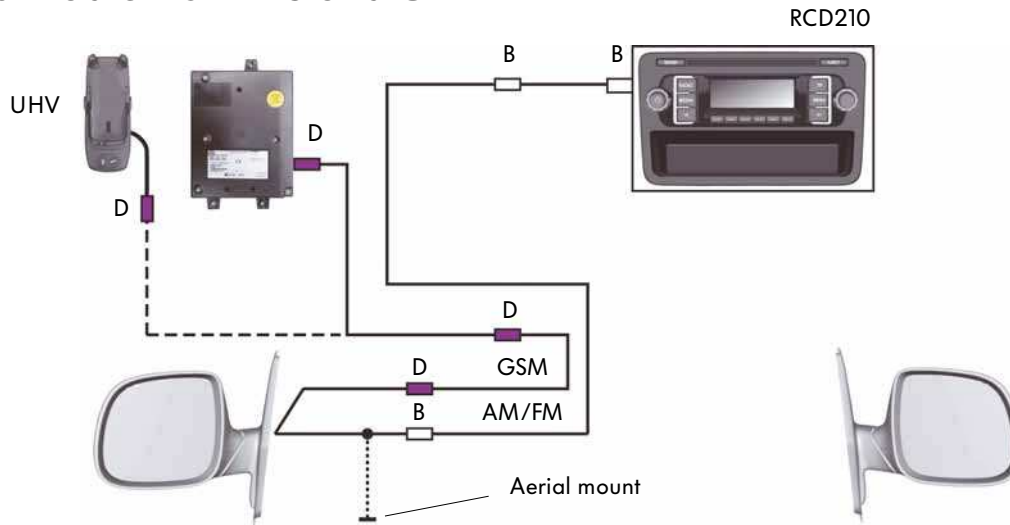

S453\_046

### Left exterior mirror

- AM/FM aerial
- GSM aerial (with UHV)

### Right exterior mirror

- without aerials

## Aerials - radio RCD 310 and UHV/DAB

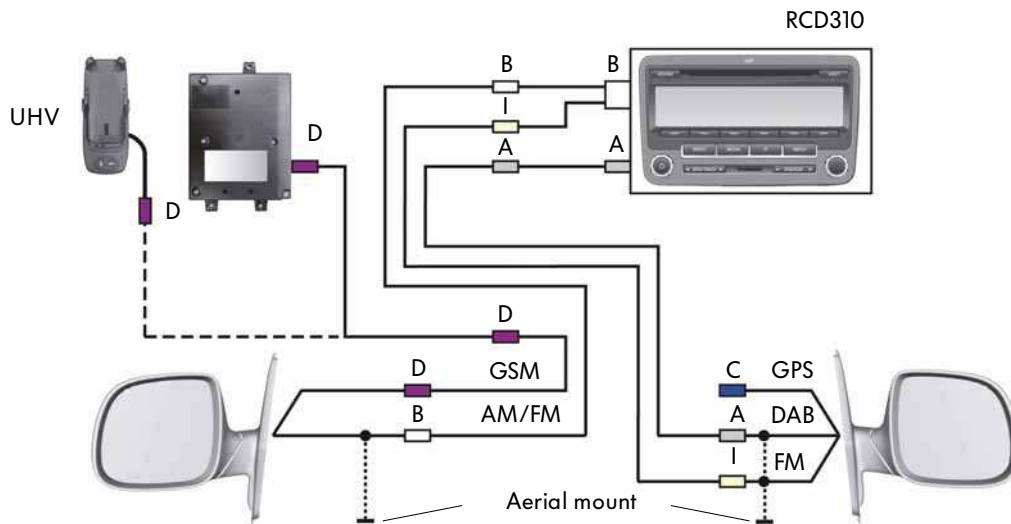

456\_047

### Left exterior mirror

- AM/FM aerial
- GSM aerial (with UHV)

### Right exterior mirror (with DAB)

- FM2/DAB aerial
- GPS aerial (not used)

### Right exterior mirror (in equipment without DAB)

- FM2 aerial



# Radio, phone and navigation

## Aerials - radio/navigation unit RNS 310 and UHV

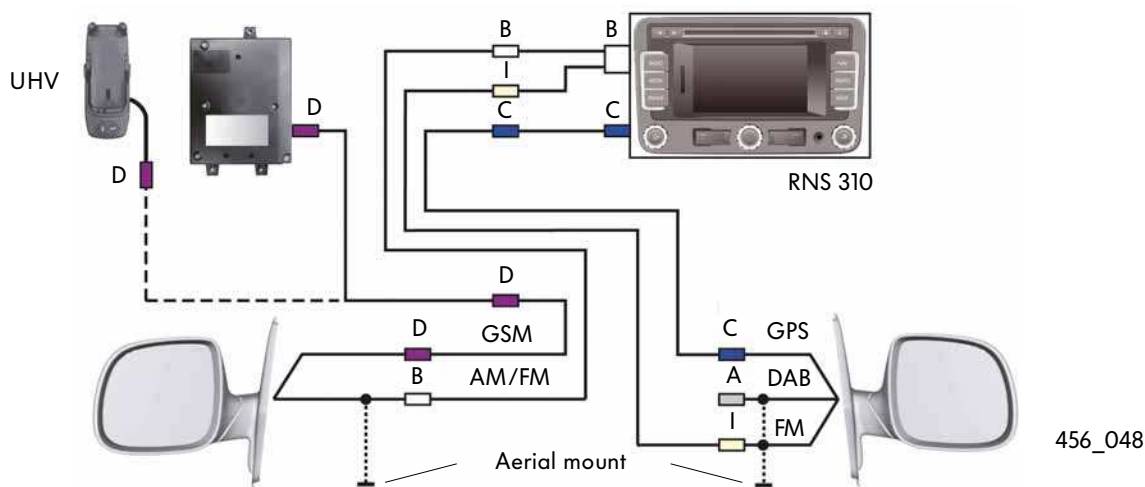

Left exterior mirror

- AM/FM aerial
- GSM aerial (with UHV)

Right exterior mirror

- FM2/DAB aerial (DAB aerial is not used)
- GPS aerial

## Aerials - radio/navigation unit RNS 510 and UHV/TV

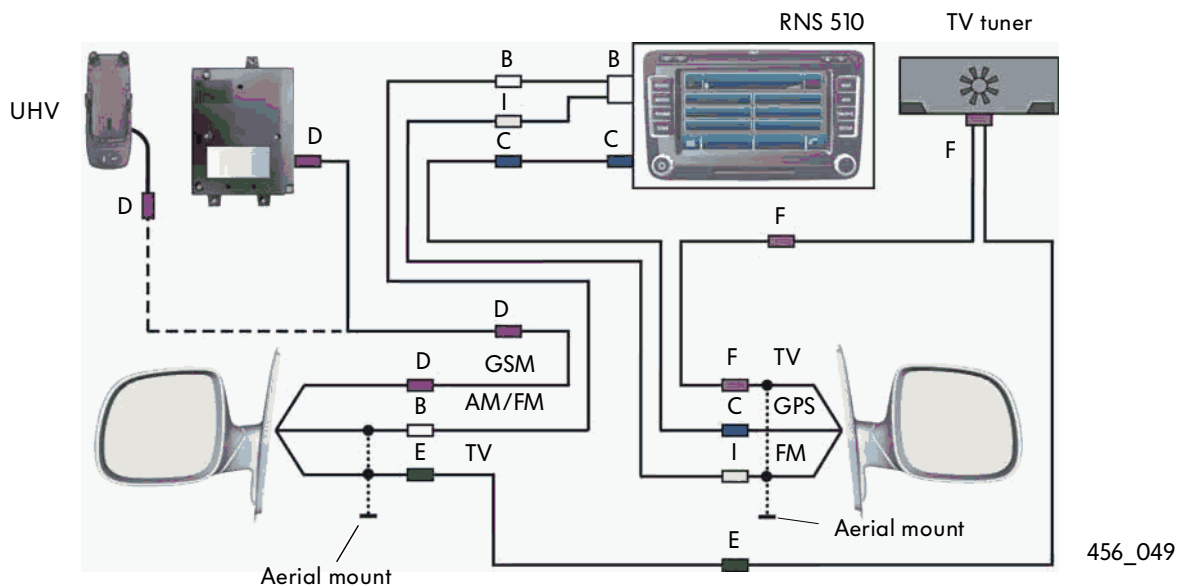

Left exterior mirror

- AM/FM/TV aerial
- GSM aerial

Right exterior mirror

- FM2/TV aerial
- GPS aerial



# The telephone preparation UHV

The telephone preparations used in the T5 2010 are UHV with audio streaming and UHV premium. These must be paired with Bluetooth™-capable mobile phones.

## UHV (Bluetooth™ low) with audio streaming

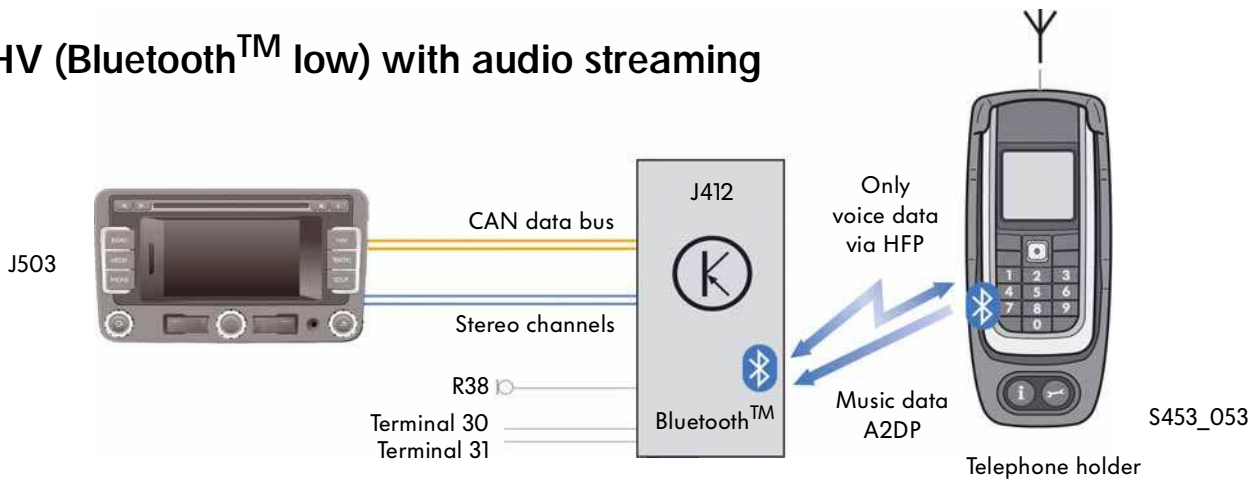

**Key**

- J412 Mobile telephone operating electronics control unit
- J503 Control unit with display for radio and navigation
- R38 Telephone microphone

## UHV premium with Bluetooth™ (rSAP)

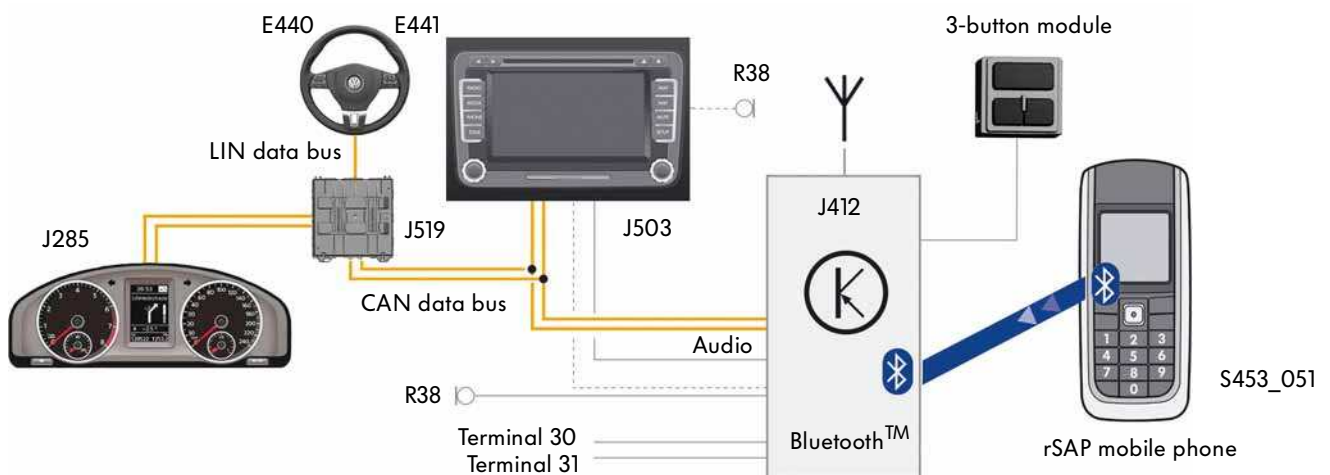

**Key**

- E440 Multifunction buttons in steering wheel left
- E441 Multifunction buttons in steering wheel right
- R38 Telephone microphone
- J285 Control unit in dash panel insert
- J412 Mobile telephone operating electronics control unit
- J503 Control unit with display for radio and navigation
- only with RNS 510



More detailed information about the UHV telephone preparations is available in self-study programme no. 423 "The Golf 2009".







453

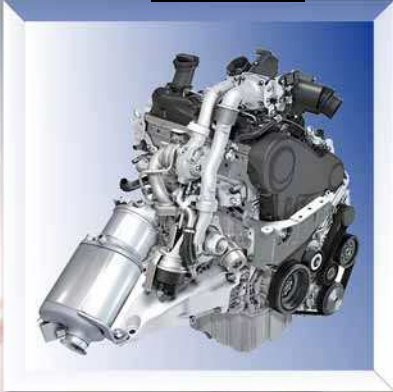

© VOLKSWAGEN AG, Wolfsburg  
All rights reserved. Subject to technical modifications.  
000.2812.33.20 Technical status 11.2009

Volkswagen AG  
After Sales Qualifizierung  
Service Training VSQ-1  
Brieffach 1995  
D-38436 Wolfsburg

 Paper made from cellulose bleached without the use of chlorine.